

Directional Control of Wheel Synchronization in Vehicle Steer by Wire System

S. M. H. Fahami¹, Faiz Mohd Turan¹.

¹Faculty of Manufacturing and Mechatronic Engineering Technology, Universiti Malaysia Pahang, 26600 Pahang, Malaysia.

ABSTRACT – In conventional steering system a drive directly control the movement of the front wheel by control the steering wheel through a mechanical column shaft. However, in steer by wire (SBW) system, the front wheel is control by electronic function due to elimination of the mechanical column shaft and are replaced with several sensors and actuator. This paper propose a control algorithm to synchronize the front wheel angle accordance to steering wheel input angle. The models of SBW system are indentified. Two control method are compare which is a PID and LQR controller is used to control the front axle motor of front axle system. The effect with and without disturbace input are applied to analyze the robustess of the controllers. To investigate the effectiveness of the proposed control algorithm, the matlab tools software is used. And, based on the result shows, both controller able to control the front wheel angle, however method using the LQR control provide more better steering response.

ARTICLE HISTORY

Received: 7th May 2022

Revised: 3rd June 2022

Accepted: 27th June 2022

KEYWORDS

Force Feedback

Steering by Wire

Torque Control

INTRODUCTION

The generation of steering system is steer by wire (SBW) system eliminate the need of steering mechanical column shaft between the steering wheel and rack pinon system. It was replaced with a sensor, actuators, and electronic controller unit (ECU) [3] as shown in Figure 1. The SBW system offer an advantages such as enhance reponse of the vehicle maneuver and stability. [1–5]. For vehicle manufacturers, the elimination of steering mechanical column shaft gives freedom of interior design and ergonomics[6-9]. Thus making it more comfortable for the driver.

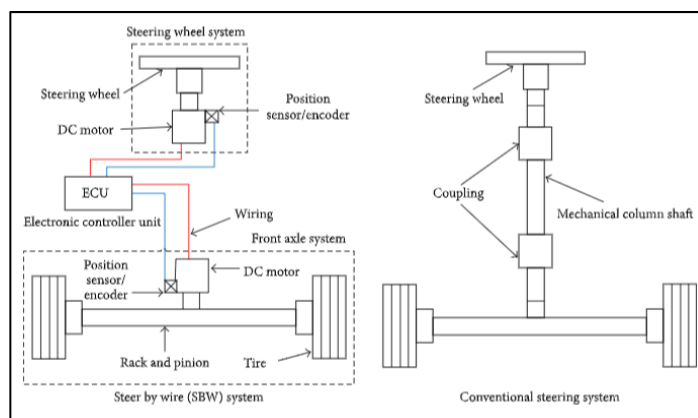

Figure 1. Steer by wire and Conventional steering system

Due to the elimination of mechanical column shaft, the front wheel angle need to be synchronize with command steering wheel input. Therefore, in order to synchronize, the method of control need to applied on the system. Several researches have be conduct a study on control method to apply such as Hiroki et al. [10], used classical controller which is PD controller to synchronize the tire front wheel angle. The advance controller, Sliding Model Control (SMC) method has been proposed by Reza et al.[11]. The controller is designed based on inertia, dampong and resistance coefficient of the front axle system. While, a full state feedback controller based on the driver steering wheel angle and vehicle speed response proposed by Yih et al. [12]. The vehicle response consists of yaw rate and lateral acceleration is taken into account to improve steering response. Futhermore, more advanced approach, which is a sliding mode learning control (SMLC) scheme, has been proposed by Manh et al. [13]. The proposed SMLC algorithm is based on the concept of the “Lipschitz-like-condition” studies by Man et al.[14]. The author claim that, the controller design does not required prior information about system uncertainties where is embeded in the Lipschitz-like condition. Moreover, SMLC is efficient adjusted to the closed loop response.

The objective of this paper is to applied control method in order to synchronize the front wheel angle based on input steering wheel of vehicle SBW system. The subsystem steering wheel , front axle system and linear vehicle model are indentified. Then, two control method are applied for wheel synchronization. In order to investigate the robutsnes of the controller, with and without disturbance a applied to the system with Matlab tools software is used to simulate the model response.

THE MODELLING OF STEERING WHEEL MODEL OF SBW SYSTEM

The model component of SBW system is divided into two subsystem which is the steering wheel and front axle system. The system diagram of models are shown in Figure 2.

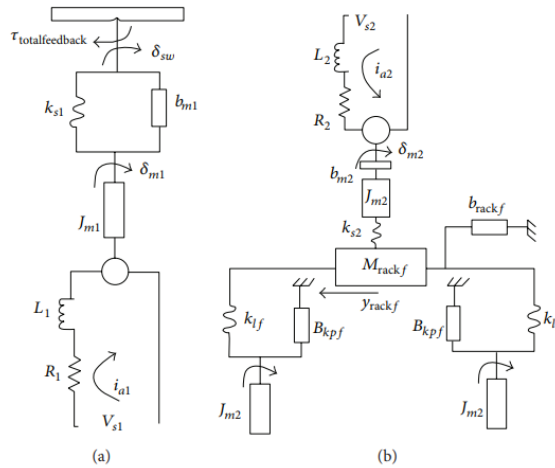

Figure 2. System diagram of Steering Wheel and front axle system [9]

The purpose of steering wheel model is to create the steering force feedback torque for driver steering feel and steering wheel returnability as desribed before previously. As shown in Figure 2(a), the input to the stering wheel system is the total force feedback torque ($\tau_{forcefeedback}$) and the rate change of steering wheel motor angular displacement ($\dot{\delta}_{m1}$), the motor angular displacement (δ_{m1}), and the current of steering wheel motor (i_{a1}) are output of the system. Meanwhile, Figure 2(b), the input to the system is steering wheel angle and the output is front wheel or tire angle. The purpose of front axle system, to ensure the front wheel angle follow the driver steering wheel angle during maneuver. The parameters for both system model defined through Ancha et al. [9].

However, in this paper, the steering wheel system model is not simulate in this study and to be assume the input steering wheel is manually applied. Basically, the steering wheel system used as force feedback torque for driver steering feel and steering returnability. This paper only focus on front axle system model to synchronize the front wheel of the vehicle.

THE MODELLING OF FRONT AXLE WHEEL SYSTEM OF SBW SYSTEM

The front axle wheel system is to ensure the front wheel angle follows the steering wheel angle command according to the steering ratio [15]. The front axle component is front axle DC motor, rack pinion system and tire model. The system diagram are shown in Figures 2(b) and 3 respectively. The input to the system is the steering wheel angle (δ_{sw}). While the output of the model is front wheel angle (δ_f). And in between there is input and output of front axle motor angle (δ_{m2}) and rack displacement (y_{rack}).

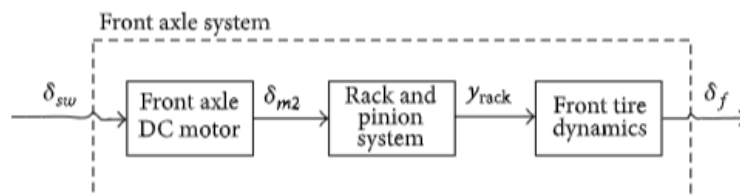

Figure 3. Front Axle Wheel system

SINGLE TRACK - LINEAR VEHICLE MODEL

The vehicle stability characteristics are affected influence by the front tires via the feedback of the vehicle dynamic response. Thus, this paper used a single track-linear vehicle model [16] to track the dynamic reponse and is used to generate the estimation self aligning torque (τ_a) as shown in Figure 4 and Figure 5 as disturbance input to the front axle system model. The yaw rate and vehicle body slip angle are the output of the model.

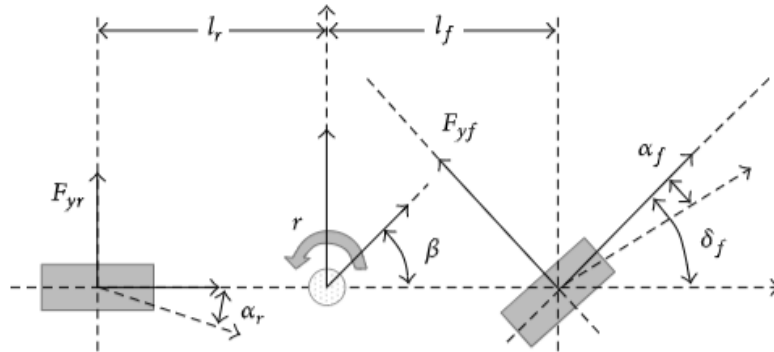

Figure 4. Single Track Linear Vehicle Model

The following assumptions are considered for normal driving maneuverer. These assumptions could simplify the vehicle model [17]:

- (i) friction force in the -direction is negligible,
- (ii) vehicle speed is constant
- (iii) Maximum vehicle speed applied at 120km/h

CONTROL ALGORITHM OF DIRECTIONAL CONTROL FOR VEHICLE STEER BY WIRE SYSTEM

It has been known, that in SBW system, the is mechanical column shaft eliminated and its replaced with actuators and sensors. Therefore, it is necessary to apply a control function that able to synchronize the front wheel with the steering wheel input command. Furthermore, the controller apply should be able to handle an external disturbance, with a quick response and minimal tracking error.

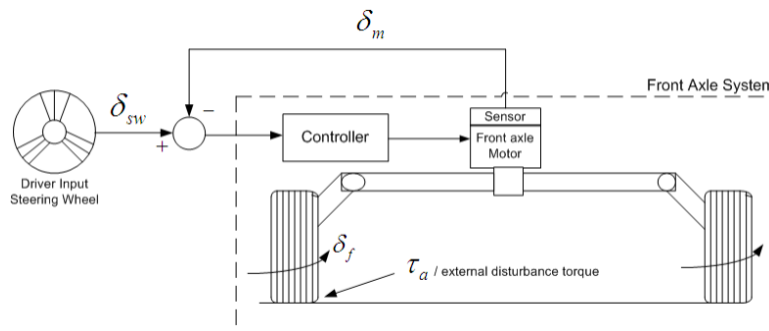

Figure 5. Front Axle Wheel System

The Figure 5 and Figure 6 shows a view and control block diagram of the front axle system. The motor position of front axle wheel system is a feedback to the controller and used to track the actual position of the motor to the desired command driver steering wheel. The correct controller gain provide a quick response for the front wheel angle to move with a minimal tracking error. In order to have an influence to the front wheel with a road contact, the self self-aligning torque is assumed to be an external disturbance that can cause a tracking error. In order, to reduce a error, the Proportional – Integral – Deravative (PID) and Linear Quadratic Regulator are used to control a motor position for front axle wheel system and both controller are then compare for the output response performance.

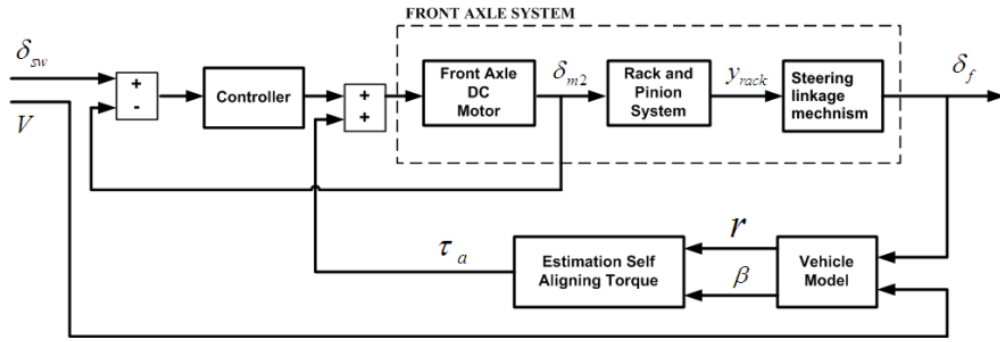

Figure 6. Control block Diagram of Front Axle Wheel System

The Proportional, Integral and Derivative (PID) controller

The Proportional-Integral-Derivative (PID) controller as a conventional control is widely used in industrial control systems. This is due to its simplified of control design and efficient tool that deal with a real control problem. The PID controller action, performed on the error signal is written as follows;

$$U(t) = k_p e(t) + k_i \int_0^t e(t) dt + k_d \frac{de}{dt}$$

where $U(t)$ is the control output to the plant and $e(t)$ is the error difference between the input and output signal of the system. The (k_p) is the proportional gain, whereby type of all pass gain factor and applies on all frequencies in error signal. The (k_i) is the integral gain is more prominent on low frequencies of error signal and thus it used to eliminate the steady state error. While, (k_d) is the derivative gain provides high frequencies compensation and thus *improving* transient response. The method of tuning the gains of PID can be defined using Ziegler Nicholas Method.

The Linear Quadratic Regulator (LQR) controller

The Linear Quadratic Regulator (LQR) controller is a control scheme provides the possible performance with depend on given measured response. The stability of the controller is effect a time response, overshoot and steady state by changing the location of poles to the optimal location. The state feedback controller K is designed in such way that the cost function J is minimized to reduce the error in order to achieve some compromise between the use of control effort and the magnitude that stabilize the system.

The optimal LQR problem is often defined more generally and consisted of the controller transfer matrix that minimizes the cost function J as written in the following;

$$J = \int_0^\infty (x^T Q x + u^T R u) dt$$

Where x^T and u^T are respectively represent by the transpose of the state and input vector. The Q and R are the positive definite (or positive-semi definite) of real symmetric matrix. The Q and R are usually chosen to be diagonal matrix and written using Bryson rule as follows;

$$Q_{ii} = \frac{1}{\text{Maximum Acceptable Value of } x_i^2}$$

$$R_{jj} = \frac{1}{\text{Maximum Acceptable Value of } u_j^2}$$

Where;

- $i = \in \{1, 2, \dots, i\}$
- $j = \in \{1, 2, \dots, j\}$

In order to analysis the performance for both controllers, there are several justification that has been made to achieve the function of wheel synchronization. The output motor position of front wheel system should have:

- settling time should less than 1.3 sec.
- overshoot should less than 3%.
- zero steady state error.

The Figure 7 below, show comparison of two method of control which is PID and LQR controller when the output is front wheel motor and the input is step function of front axle system The comparison of settling time, steady state error and overshoot are illustrated in Table 1.1

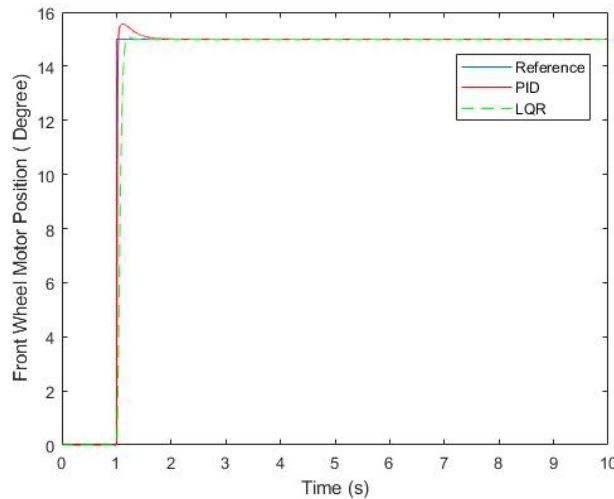

Figure 7. Comparison PID and LQR controller without disturbance input

Table 1. Controller performances

Type of Controller	Settling Time (Ts)	Overshoot (OS %)
PID Controller	2.00 sec	3.67 %
LQR Controller	1.35 sec	0.5 %

Based on the result shown in Table 1, the PID controller offer a fast response on movement of front wheel motor position compare to LQR controller. However, the settling time of LQR controller is more faster then PID controller. Moreover, the overshoot of PID controller is more than 3% compare to LQR controller. The further analysis investigate effect of self aligning torque as disturbance to the system in order to achieve a justification for the wheel synchronization in SBW system application.

Self Aligning Torque as Disturbance to the system

The self-aligning torque (τ_a) of the tyre is a function of the steering geometry and also the deformation of the tyres which generates lateral forces [12]. It is a torque that create from contact between wheel and road surfaces as shown in Figure 6. This torque make the steering wheel return to initial positon when release hand-off and create the steering feel for driver maneuver. Therefore, the estimation of self-aligning torque is written as follows;

$$\tau_a = -C_f(t_p + t_m) \left[\beta + \frac{l_f}{V} r - \delta_f \right] \quad (1)$$

Whereby, the front cornering stiffness (C_f), body slip angle (β), yaw rate (r), vehicle speed (V), pneumatic trail (t_p), mechanical trail (t_m), front tire angle (δ_f) and from the center of the front wheel to the vehicle body center of gravity (C.O.G) is (l_f).

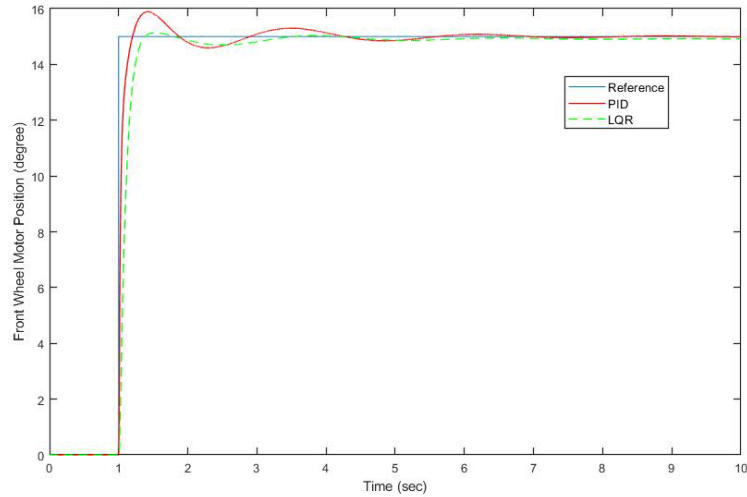

Figure 8. Comparison PID and LQR controller performance with disturbance input

Based on the Figure 8, it can be seen that, when disturbance a applied to the front wheel system, it gives an effect to the front wheel motor position for both controllers in parallel there is very small direction change of front wheel angle. Moreover, the overshoot of PID increased compare without applied a disturbance. Meanwhile, the oscillation of the response is quite large before its reach a steady state value and a settling time almost reach at 6.5 sec. And its differ from method of LQR controller, the control give less of overshoot and the oscillation response is small compare to PID controller.

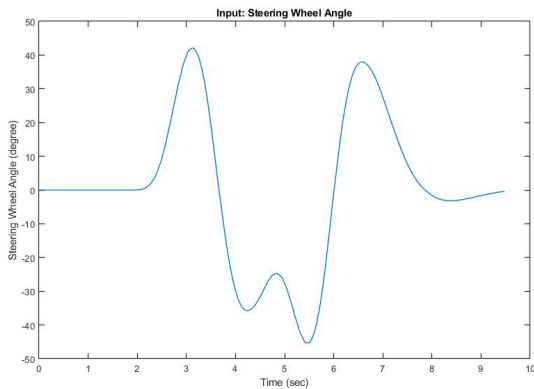

Figure 10. Input Steering Wheel Angle

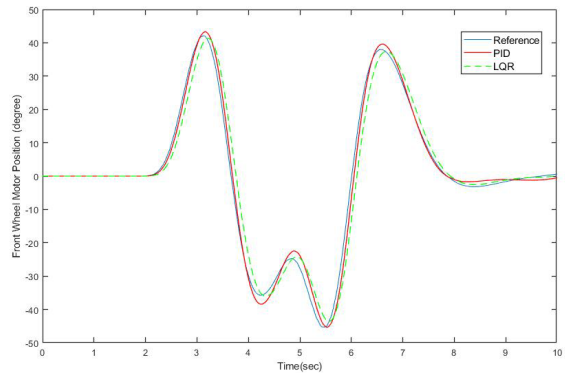

Figure 11. Motor Position – Front Wheel System

Table 2. Front Wheel Motor Position – Controller Performance

Type of Controller	RMS Value	Similarity (%) to references
Reference	21.85	-
PID Controller	19.23	88.00
LQR Controller	20.47	93.68

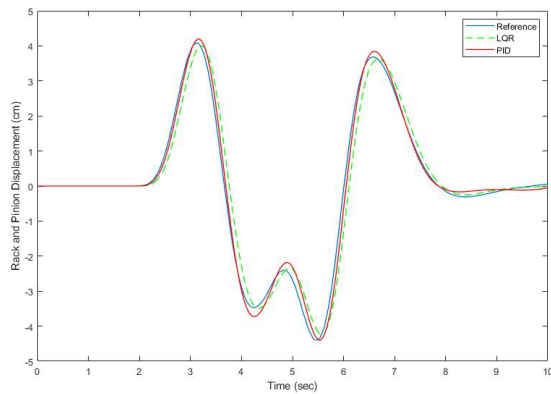

Figure 12. Rack and Pinion Displacement

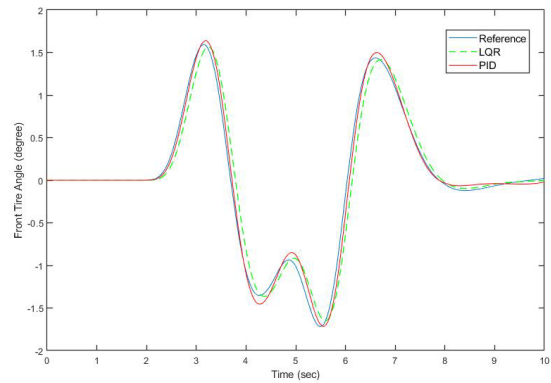

Figure 13. Front Tire Angle

The response of front wheel motor position, rack and pinion displacement and the front tire angle are shown in Figure 11, 12 and 13., when the input steering wheel angle is a double lane change maneuver as shown in Figure 10, vehicle speed at 120km/h. Based on the results shows, both controller able to follow the reference response. However, the LQR controller offer more similarity 93% to reference response compare to PID controller which is 88%. This is because the multiple information feedback from the LQR controller such as rate, position and current of the motor give affect to reduce a cost function and in parallel makes a fast correction to improve signal response.

CONCLUSION

Based on the control method applied, a LQR controller offer more better synchronization of front wheel angle based on input steering wheel command. When, disturbance of self aligning torque is applied to the system, the LQR controller still can offer a better response compare to PID controller with a very small acceptable oscillation. The performance of LQR controller provide 93% similar to references response compare to PID control which is 88%. Its is important the controller to have fast response and less of oscillation during maneuver for driver safety and this a show by the LQR controller whereby a multiple information feedback from LQR control lead to reduce the cost function and in parallel accelerate reduce an error different. Even there is small different error, however with wide range adjustment gain of LQR controller can provide better result of steering response.

References

- [1] Y. Yao, "Vehicle steer-by-wire system control," SAE Technical Paper 2006-01-1175, 2006
- [2] E.A. Kumar, D. Dinesh, and N. Kamble, "An overview of Active Front Steering System" International Journal of Scientific & Engineering Research, vol. 3, no. 6, 2012
- [3] S.M.H. Fahami, H. Zamzuri, S. A. Mazlan, and N. B. Zulkarnain, " The design of vehicle Active Front Steering based on steer by wire system" Advanced Science Letters, Vol. 19, no.1, pp.61-65, 2013
- [4] S.M.H. Fahami, H. Zamzuri, S. A. Mazlan, and S.A.Saruchi, " The variable steering ratio for vehicle steer by wire system using hyperbolic tangent method" Applied Mechanics and Materials, vol.575, pp.781-784, 2014.
- [5] S.Amberkare, F.Bolourchi, J.Demerly, and S. Millsap " A control system methodology for steer by wire system, SAE Technical Paper 2004-01-1106, 2004.
- [6] A.Baviskar, J.R.Wagner, D.M. Dawson,D.Braganza and P.Setlur, " An adjustable steer by wire haptic-interface tracking controller for ground vehicle" IEEE Transaction on Vehicular Technology, vol.58, no.2, pp.546-554, 2009
- [7] C. J. Kim, J. H. Jang, S. K. Oh, J. Y. Lee, and J. K.Hedrick," Development of a control algorithm for a rack-actuating steer-by-wire system using road information feedback," Proceedings of the Institution of Mechanical Engineers Part D: Journal of Automobile Engineering, vol. 222, no.9, pp. 1559-1571, 2008
- [8] D. Odenhtal, T. Bunte, H. D. Heitzer, and C. Eicker," How to make steer-by- wire feel like a power steering" in

Proceedings of the 15th IFAC World Congress Barcelona, Spain, July 2000.

- [9] S.Ancha, A.Baviskar, J.R.Wagner, and D.M. Dawson, " Ground vehicle steering system: Modelling, control and analysis of hydraulic, electric and steer by wire configurations." *International Journal of Vehicle Design* vol. 44, no.1-2, pp.188-208, 2007
- [10] Hiroki, O. and Murakami, T. A stability Control by Active Angle Control of Front Wheel in a Vehicle System. *IEEE Transaction on Industrial Electronics*, 2008. 55(3): pp.1277–1285
- [11] Reza, K., Mousavinejad, I., Rafat, M. and Khaknejad, M. B. Yaw Moment Control of the Passenger Car via Steer by Wire System. *Proceedings of the International Mechanical Engineering Congress Exposition ASME 2011, Colorado, USA, 2011. (62474): pp.1–9*
- [12] Yih, P. and Gerdes, J. Modification of vehicle handling characteristics via steer by wire. *IEEE Transaction on Control System Technology*, 2005. 13(6): pp.965–976.
- [13] Manh, T. D., Man, Z., Zhang, C., Wang, H. and Tay, F. S. Robust Sliding Mode-Based Learning Control for Steer-by-Wire Systems in Modern Vehicles. *IEEE TRANSACTIONS ON VEHICULAR TECHNOLOGY*, 2014. 63: pp.580–590.
- [14] Z.Man, S.Khoo, X.Yu and J.Jin. A new sliding mode-based learning control scheme. *Industrial Electronics and Applications (ICIEA), 6th IEEE Conference, Beijing, China, 2011: pp.1906191*
- [15] Kumar, E. and Kamble, D. D. N. An Overview of Active Front Steering System. *International Journal of Scientific Engineering Research*, 2012. Vol.3, Issue 6
- [16] Rath, M., Kelly, M., Kober, K. and Gulati, A. Optimum Design of a Steer by Wire System using Systematic System Engineering Approach. *SAE Technical Paper Series, 2008-01-1452.*
- [17] Zhang, L., Wang, L. and Liao, C. Reliability Research for Steer-by-Wire System of Electric Vehicle. *Power and Energy Engineering Conference, APPEEC 2009. Asia-Pacific, Wuhan, China, 2009: pp.1–4.*