

# Feeder Load Balancing Using Genetic Algorithms and Artificial Neural Network

Aminu Adaira Suleiman<sup>1</sup>, Kafayat Oluwatoyin Shobowale<sup>2</sup>, Kumater Peter Ter<sup>2</sup>, Yusuf Samuel Sunday<sup>3</sup>, Razak Otokititi<sup>4</sup>, Mathias Usman Bonet<sup>2</sup> and Aul Marcus Maafan<sup>2</sup>

<sup>1</sup>Department of Electrical Engineering, Bayero University Kano, Nigeria

<sup>2</sup>Faculty of Air Engineering, Air Force Institute of Technology Kaduna, Nigeria

<sup>3</sup>Department of Electrical Engineering, Ahmadu Bello University Zaria, Nigeria

<sup>4</sup>Department of Electrical Engineering, Federal University of Technology Minna, Nigeria

**ABSTRACT** – Low voltage power distribution system problems such as system planning, energy loss minimization and restoration usually involve proper load balancing or network reconfiguration procedures. To achieve an appreciable level of load phase balance, feeder reconfiguration using appropriate switching control strategy such as: Simulated Annealing, Tabu Search, Particle Swarm Optimization, and heuristic algorithms are viable preferences. However, the systematic solution to load phase balancing can be greatly enhanced optimally through implementation of an appropriate combinatorial optimization procedure such as Genetic Algorithms and Artificial Neural Network. Accordingly, this paper presents a genetic algorithms procedure to enhance the load phase balancing optimization and then train an artificial neural network to automate the reconfiguration of the distribution network loads, thus ensuring an optimal phase balancing in the system. An Intel® 2.0 GHz, 4GB RAM HP255 computer-based MATLAB® 14 was used for the neural network training, testing, and the implementation of the genetic algorithms. The outputs of the algorithms are the switching sequence for a balanced network. The parameters  $\Delta I_{ph}$  (max - min) and  $\Delta(I_{ph} - I_{max})$  which is the maximum difference between the phase currents, which are ideally zero if there are no imbalances in the network, shows considerable improvement in the balancing when compared with other literatures. This work presents the application examples of the proposed methods using real test data.

## ARTICLE HISTORY

Received: 21<sup>st</sup> April 2022

Revised: 18<sup>th</sup> May 2022

Accepted: 15<sup>th</sup> June 2022

## KEYWORDS

Artificial Neural Network  
Genetic Algorithms  
Load Balancing  
Network Reconfiguration  
Power Distribution Feeder

## INTRODUCTION

Optimal planning and design of the power distribution systems involves network reconfiguration for distribution loss minimization, load balancing under normal operating conditions, and fast restoration of supply to minimize zones without power under failure conditions [1]. Most of the distribution networks are configured radially [2, 3] which simplifies over-current protection of the feeders; hence the manual or automatic switching operations is performed to vary the configurations. Feeder reconfiguration in the distribution system has different needs: from balancing the loads in the network, to minimizing the losses in the system and as well as to correct the voltage profile of supply phases, and so forth [4]. There are numbers of normally closed/opened switches in distribution system, and by changing the open/close status of these feeder switches, load currents are transferred from feeder to feeder; that is, from the heavily loaded feeder to the less loaded feeder, hence ensuring a relatively balanced network [4].

## PROBLEM DESCRIPTION

### *Load Balancing*

The continuous growth in electrical energy demand and pressing need for better quality of service has necessitated the need for continuous load balancing along a distribution network [5]. Over time, distribution feeders have tendency to increase in load unbalance due to the following:

- Loads on single-phase lines may gradually increase.
- Single-phase lines arbitrarily get manually switched to other phases.
- Unequal distribution of single-phase loads on three phase lines.
- Lack of proper system planning.

The results of the aforementioned are:

- Voltage phase shifts deviating from the  $120^\circ$ .
- Increased return currents in the neutral conductor.
- Increased losses due to excessive unnecessary currents.
- Over-voltages and under-voltages occurring at different points of the feeder.

In Lokoja metropolis, like every other metropolitan city in the country, reducing an unbalance load in a distribution feeder requires the connected phases of the feeder to be manually switched - after some field measurements are maybe carried out. This manual rearrangement of the phases is mostly time consuming and at most times, unsuccessful [6-8]. However, with the use of an optimization model such as genetic algorithms and a dynamic balancing technique such as neural network, reconfiguration of feeder load in the system become easier, effortless and efficient. The load optimization by the genetic algorithm involves the methodology of making the best combination set of the loads in each phase of the network to ensure the entire system is balanced. This can be applied in a feeder networks of many load points such as eighteen (18) houses considered in this paper as the unbalanced loads shown in Figure 1. And by properly performing the switching operation, the power demand of these houses can be evenly distributed across the three (3) phases i.e, by transferring loads from the heavily loaded feeder to the lightly loaded ones so that the distribution system will become more balanced and the risk of overloading can be reduced.

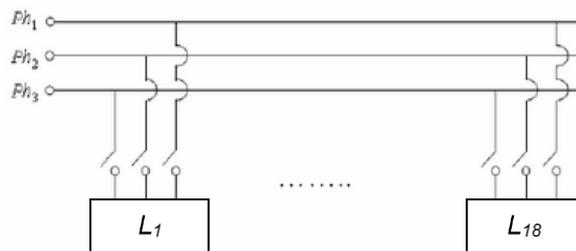

**Figure 1.** LV Distribution Feeder Network

### *Feeder Reconfiguration*

The automation of the power distribution system is technically advantageous and as well as economical, for the electricity consumers and vendors, in terms of better quality and costs reduction respectively. Considering the volatility of loads across the network, and owing to the fact that the engineers do not have an absolute control of the number of loads connecting to a feeder at a particular point in time [9-11], it is absolutely necessary implementing a scheme to normalize the loads on each feeder in order to prevent overload. Likewise, as the power system changes to smart grid, the penetration of distributed generation grows, and this complicates the system such as an irregular voltage profile, hence reconfiguration of the load helps in normalizing the voltage profile of the system [6], [12, 13]. This reconfiguration entails the switching ON and OFF of the different switches, hence allowing the three phase supply by the transformer to the end-users to be balanced.

### *Research Gap*

Many reviewed literatures engage different kinds of approaches such as: SA, ANN, TS, PSO, heuristic algorithms etc. in solving the problem of load balancing. These procedures however do not provide an optimal solution to load phase balancing as only network reconfiguration is considered. Therefore, furtherance to ANN network reconfiguration as achieved in [6], this paper provides an enhanced solution using genetic algorithms based technique to ensure a dynamic and optimized load balancing, thus minimizing the energy losses in the network.

of using a genetic algorithm (GA) to optimize the balancing of the various loads from the consumers and then train an artificial neural network (ANN) with the optimized data to automate the dynamic switching sequence of switches along the distribution network, hence keeping the load phases balanced.

The implementation of these algorithms aims to dynamically resolve the following:

- Unequal distribution of single-phase loads on three phase lines.
- Energy losses in a distribution feeder.
- Improper system planning.

## METHOD

### GA Technique for Load Balancing

#### Control Variable $I_k$ and Minimization of Losses

The relationship per phase between the no-load voltage ( $V_{oj}$ ), internal impedance  $Z_j$  and load current  $I_j$ , as shown in the equation (1) below where  $V_j, I_j$ , and  $Z_j$  are in complex phasor and

$$V_j = V_{oj} - Z_j I_j \quad (1)$$

Given the above dependency between voltage and load current and the fact that the impedance is constant, this paper will focus on the currents in finding the optimum loads at which the phases are balanced. Accordingly, as expressed in the objective, load balancing problem is solved in terms of minimizing the real power loss, hence;

$$P_{Loss} = \sum_{i=1}^n r_i \frac{P_i^2 + Q_i^2}{|V_i|^2} \quad (2)$$

Therefore, power loss analysis is expressed to establish the control variable.

In three-phase four wire systems, equation (2) becomes;

$$\sum_{i=1}^3 r_i \frac{P_i^2 + Q_i^2}{|V_i|^2} = \sum_{i=1}^3 r_i \frac{|V_i|^2 |I_i|^2 \cos^2 \varphi + |V_i|^2 |I_i|^2 \sin^2 \varphi}{|V_i|^2} = \sum_{i=1}^3 r_i |I_i|^2 = r_1 |I_1|^2 + r_2 |I_2|^2 + r_3 |I_3|^2 \quad (3)$$

In general, each phase has the same internal resistance  $r$  which is constant. Therefore, equation (3) can be expressed:

$$\sum_{i=1}^n r_i \frac{P_i^2 + Q_i^2}{|V_i|^2} = r (|I_1|^2 + |I_2|^2 + |I_3|^2)$$

Constraining to  $|I_1|^2 + |I_2|^2 + |I_3|^2 = c$ ,  $C$  can be a complex or real constant depending on the load. To minimize the total real power losses means:

$$\min (|I_1|^2 + |I_2|^2 + |I_3|^2), \text{ Subject to } |I_1|^2 + |I_2|^2 + |I_3|^2 = C$$

The method of Lagrange multiplier is used to solve equation (3). Create the non-constrained function as:

$$L(|I_1|, |I_2|, |I_3|, \lambda) = |I_1|^2 + |I_2|^2 + |I_3|^2 + \lambda(|I_1| + |I_2| + |I_3| - c)$$

The gradients for this new function are expressed as follows:

$$\begin{aligned} \frac{\partial L}{\partial |I_1|} &= 2|I_1| + \lambda_1 = 0 \\ \frac{\partial L}{\partial |I_2|} &= 2|I_2| + \lambda_1 = 0 \\ \frac{\partial L}{\partial |I_3|} &= 2|I_3| + \lambda_1 = 0 \\ \frac{\partial L}{\partial \lambda_1} &= |I_1| + |I_2| + |I_3| - C = 0 \end{aligned} \quad (4)$$

From equation (4), the expression below can be obtained:

$$|I_1| = |I_2| = |I_3| = \frac{1}{3} C.$$

$$\text{Therefore, when } |I_1| = |I_2| = |I_3| = \frac{1}{3} C \quad (5)$$

Then, the total real power losses are minimal.

If the loads are pure resistance, the minimum power losses are achieved; when  $p_1 = p_2 = p_3 = \frac{P}{3}$ , where  $p_i$  ( $i = 1, 2, 3$ ) is the real power per phase and  $P$  is the sum of the three phases real powers. So, we can solve the load balancing problem by distributing equally the load current or power to three phases, according to the load property.

From the expression equation (5), it has been established that the load balancing problem means all the loads are distributed to three phases equally, with minimum differences among the individual sums of three phases. So there is an ideal phase balance of *load* ( $Load_{ideal}$ ). This is equal to the one-third of the sum of all the loads in the particular reference feeder, as shown in equation (6).

$$Load_{ideal} = \frac{1}{3} \sum_{i=1}^n Load (i) \tag{6}$$

$n$  is the number of all the loads in the three phases of the feeder. The load balancing is complete if the sum of every phase loads satisfies equation (7) below.

$$\sum_{i=1}^m Load (i) = Load_{ideal} \tag{7}$$

Where  $m$  is the number of load points which are connected to one phase, therefore, in a three-phase four-wire system, we have load balancing when

$$Load_{phase1} \cong Load_{phase2} \cong Load_{phase3} \tag{8}$$

### GENETIC ALGORITHMS MODELING

The Phase Contactor Method is applied in the GA modeling whose variables are as follow:

Load current magnitude at node  $k$  given by  $I_k$ .

Load current phase angle at node  $k$  given by  $\varphi_k$ .

Phase at which this particular node is to be connected (1, 2 or 3) corresponding to phases (R, Y or B).

The first two values of the gene are fixed during the whole optimization problem since it includes the original system data. The only variable that is allowed to change is the phase connection of each gene. Table 1 shows the values of the phase connection and the corresponding values of  $A_k$ ,  $B_k$  and  $C_k$ .

**Table 1.** Phase Connection Values

Phase	$A_k$	$B_k$	$C_k$
1	1	0	0
2	0	1	0
3	0	0	1

The main task of applying any solution to the system relies on the formulation of the problem. The first task is to identify the control variable. In this case, it is the balancing of phase loads in order to reduce the neutral current to minimum. The currents magnitude of load  $k$  is given by  $I_k$  at each node (load) as well as its corresponding power factor angle ( $\varphi_k$ ). This current in phasor format will be added to the total current of each phase depending upon its corresponding connection. The three total phase currents  $I_k$  are given by:

$$\begin{aligned}
 I_{tot}^{-A} &= \sum_{k=1}^{N_{Id}} A_k \cdot I_k^- \\
 I_{tot}^{-B} &= \sum_{k=1}^{N_{Id}} B_k \cdot I_k^- \cdot a \\
 I_{tot}^{-C} &= \sum_{k=1}^{N_{Id}} C_k \cdot I_k^- \cdot a^2
 \end{aligned} \tag{9}$$

Where:  $a = 1 < 120$  and  $A_k$ ,  $B_k$  and  $C_k$  are three binary variables (0 or 1) corresponding to the whether the corresponding load current at node  $k$  is connected (value = 1) or not connected (value = 0) to that particular phase.

In order to reach the balanced loading condition, the neutral current is given by the equation:

$$I_N^- = I_{tot}^{-A} + I_{tot}^{-B} + I_{tot}^{-C} \quad (9)$$

In equation (10), only the total neutral current of all loads is considered for the optimization. The optimization (in this case a minimization of  $I_N$ ) is subject to the constraint that it should only consider moving each load as a whole from one phase to another in determining the optimal distribution of the load currents across the three phases of the electric feeder. Another constraint applied to the system is that the three phases should be loaded almost equally; i.e., the current magnitudes in the three phases must be almost equal to within a certain percentage of unbalance determined by the operator of the electric power system.

The figure 2 shows the procedure in finding the optimum three sets of six loads (chromosome), with minimum differences among the individual sums of the three sets (nodes). To achieve this, the ideal phase balance current value  $I_{ideal}$ , which is equal to the one-third of the sum of the all 18 load currents  $I_L$  is first calculated (Equation 6).

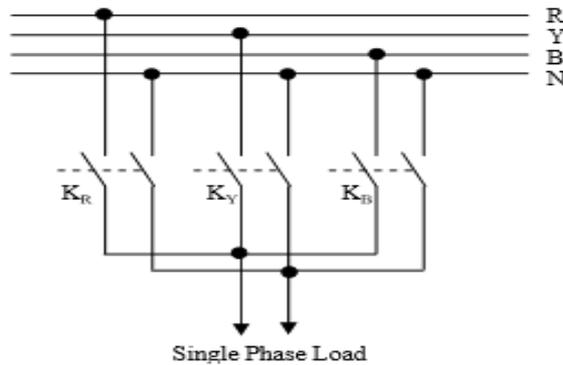

**Figure 2.** Phase Contractor Method.

The currents magnitude of load  $k$  is given by  $I_k$  at each node (load) as well as its corresponding power factor angle ( $\phi_k$ ).

### C. Implementation of the GA

For the purpose of load balancing of a Low Voltage (LV) power distribution system, a genetic algorithms-based method is implemented on the sample of the distribution system shown in Figure 1 which consists of 18 loads, each having three switches to the various phases in the system. The logic of load connection is that: for each load, only one switch should be closed, other two should remain open, i.e., each load should be connected to only one of the three phases. The load currents are referred here by the term “load.” The following initial assumptions are considered for the proposed algorithms.

The present Algorithms should be applied to 18 loads only.

The loads should be considered equally distributed per phase, i.e., 6 loads to be connected per phase.

The problem, therefore, is: to find the optimum three sets of six loads, with minimum differences among the individual sums of the three sets. To achieve this:

Firstly, the ideal phase balance load value  $I_{ideal}$  is calculated, and this should be equal to the one-third of the sum of the all 18 load currents  $I_L$

$$I_{ideal} = \frac{1}{3} \sum_{j=1}^{18} I_{Lj} \quad (11)$$

Then 3 sets of currents for the three phase currents  $I_{ph}$ , each set comprising of 18 load currents optimally select.

$$I_{load} = \{I_j, j = 1, 2, \dots, 18\}$$

$$I_{ph} = \{I_j, j = 1, 2, \dots, 6\} \text{ where } I_j \in I_{load}$$

Difference between the individual sum of these sets and the  $I_{ideal}$  should be minimum, ideally 0 for the perfect phase balance. So, three sets of  $\{I_j, j = 1, 2, \dots, 6\}$  have to be found, subject to the constraint:

$$\min \left| \sum_{j=1}^6 I_j - I_{ideal} \right|, \text{ where } I_j \in I_{load} \quad (12)$$

The implementation takes as input, the sequence of 18 load currents. It returns as output, the sequence of the switch closing for each load, i.e., integer 1, 2, or 3 for each load, where 1, 2, 3 represents the switches for the respective phase 1, phase 2 and phase 3 as shown in Figure 3. Using the output switch closing sequence and the load currents, we can calculate the three balanced phase currents and the differences between them, which indicate the quality of the phase balance.

### GA Program Outline (Pseudo-code)

The main algorithms for the implementation of the GA method are as follows.

- i. The 18 load currents are considered as the input vector;
- ii. The output vector of the switching sequences is initialized for each load, which is also a vector of 18 elements;
- iii. Then the  $I_{ideal}$  is computed using equation (12);
- iv. Check all the 18 loads to find the first set of ten load currents, i.e., for  $I_{ph1}$  optimally ON to  $I_{ideal}$ . This is done by the subroutine “Calculate set of 6” using equation (6) and explained later in the subroutine Algorithms outline;
- v. The output switching sequence for  $I_{ph1}$  is updated by marking it “1”;
- vi. Then remaining 18 loads are checked to find the second set of 6 load currents, i.e., for  $I_{ph2}$  optimally ON to  $I_{ideal}$ . This is also done by the subroutine: “set of 6 loads”;
- vii. The output switching sequences for  $I_{ph2}$  is updated by marking those 2;
- viii. After finding the sequences for  $I_{ph1}$  and  $I_{ph2}$ , the rest 6 load currents will be allocated to  $I_{ph3}$ ;
- ix. The output switching sequences for  $I_{ph3}$  will be updated by marking those 3;
- x. The output switching sequences of 1, 2, and 3 for  $I_{ph1}$ ,  $I_{ph2}$  and  $I_{ph3}$  and the corresponding input load currents, the balancing between phase currents  $I_{ph1}$ ,  $I_{ph2}$ , and  $I_{ph3}$  is computed; “For example,  $I_{ph1}$  is calculated by adding all the 6 load currents corresponding to the output switching sequences marked 1”.
- xi. “The differences between  $I_{ph1}$ ,  $I_{ph2}$  and  $I_{ph3}$  is calculated which ideally should be zero. It indicates the quality of the phase balance”.

The Program Returns:

- i. The output switching sequence.
- ii. The phase currents  $I_{ph1}$ ,  $I_{ph2}$  and  $I_{ph3}$ .
- iii. The differences between the phase currents.

Subroutine

The subroutine “Calculate set of 6” used to choose the output sequences for  $I_{ph1}$  and  $I_{ph2}$  is presented; the sequential steps:

- i. For  $I_{ph1}$ , we start with the 18 load currents;
- ii. Mark the first element as 1;
- iii. Iterate over 17 load currents for every possible combinations of the set of 5 load currents. The position of the elements in the sets are placed independently, i.e., {1, 2, 3, 4, 5} may appear in the like of {2, 1, 5, 4, 3,} or {5, 2, 1, 4, 3};
- iv. For each possible set, the difference parameter ( $\epsilon$ ) is calculated;

$$\epsilon = |I_{ideal} - \sum_{j=1}^5 I_j - \text{first current}|, \text{ as obtained in Equation 13;}$$

- v. Choose the set with the minimum value of  $\epsilon$  as the optimum balance set; The program returns the set for the  $I_{ph1}$ ;
- vi. For  $I_{ph2}$ , start with the rest 12<sup>th</sup> load currents;
- vii. Mark the first element as 2;
- viii. Iterate over eleven (11) load currents for every possible combinations of the set of nine (5) load currents. The elements in the sets are placed position independently, i.e., {1, 2, 3, 4} may appear in the like of {2, 1, 5, 4, 3,} or {5, 2, 1, 4, 3};
- ix. For each possible set, the difference parameter ( $\epsilon$ ) is calculated in equation 13;
- x. Choose the set with the minimum value of  $\epsilon$  as the optimum balance set;
- xi. Return the set for the  $I_{ph2}$ ;
- xii. For  $I_{ph3}$ , start with the rest 6 load currents;
- xiii. Return the set for the  $I_{ph3}$ ;
- xiv. Training of ANN for Network Reconfiguration

E.Training of ANN for Network Reconfiguration

Switch Selector

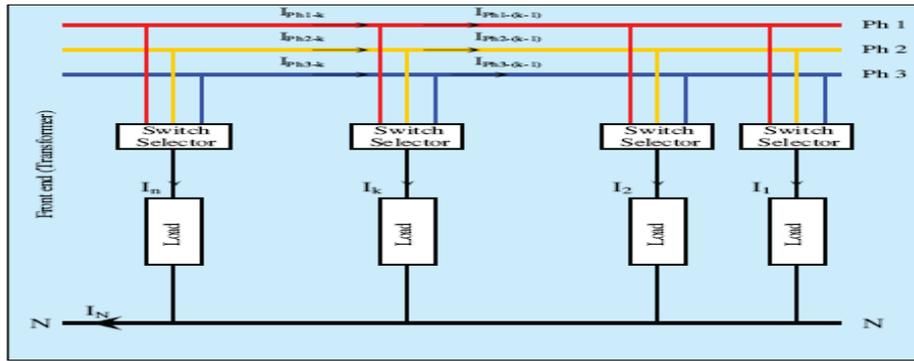

**Figure 3.** Feeder Switching Model

The switch selector as indicated in Figure 3 depicts the proposed strategy. The switch is trained to control the opening/closing sequence of each load in the network; with this it will be able to automatically reconfigure and realign the networks such that loads are transferred from the heavily loaded feeder to the less loaded feeder, and thereby ensuring a uniform and optimal phase balance. The feeder switching mechanism is shown in Figure 4.

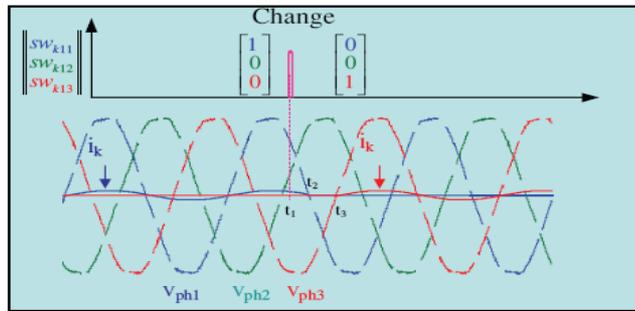

**Figure 4.** Feeder Switching Mechanism

Figure 4 shows the switching mechanism: at moment  $t_1$ , the reconfiguration Algorithms decides the load  $I_k$  should be changed from phase 1 - 3. The switch controller switches OFF the connection with phase 1 at zero crossing – moment  $t_2$  and connects the load with the phase 3 at the next zero crossing – moment  $t_3$ . The switching from one phase to another will be seen as deep with the maximum duration of 17 msec; this very short deep happened at such a fast rate that it does not affect any appliance in the house hold.

**Table 2.** Phase Currents Switching Sequence.

Data Set (A)	Unbalanced Load T1	T1 Balanced Load		Unbalanced Load T2	T 2 Balanced Load	
		GA [Sw]	NN [Sw]		GA [Sw]	NN [Sw]
Load Centres	$I_L(A)$			$I_L(A)$		
1	40.95	1	1	76.68	2	3
2	62.67	1	3	54.18	2	1
3	111.96	2	1	72.39	1	3
4	73.17	1	1	54.21	1	3
5	31.26	2	2	53.01	3	1
6	68.67	3	2	95.25	1	1
7	69.33	2	3	56.32	3	2
8	63.96	3	3	68.79	3	3
9	50.68	2	2	62.64	2	2
10	64.74	3	3	67.95	1	2
11	95.43	3	2	85.83	2	2
12	79.59	1	3	74.82	3	1
13	53.16	2	3	34.93	3	1
14	72.61	2	1	32.5	2	3
15	82.77	1	2	40.97	1	2
16	38.61	3	1	23.75	3	2

17	50.47	1	1	20.07	3	3
18	57.73	3	2	19.67	2	1
<b>1167.76</b>		<b>993.96</b>				

**Table 3.** Summary of the Results

Load Parameter	Unbalanced Load T1	Balanced GA T1	Balanced NN T1	Unbalanced Load T2	Balanced GA T2	Balanced NN T2
I <sub>ph1</sub> (A)	339.96	389.62	387.77	313.84	330.77	331.86
I <sub>ph2</sub> (A)	376.40	389.10	386.54	314.38	331.50	337.46
I <sub>ph3</sub> (A)	451.40	389.04	393.45	365.74	331.69	324.64
Total Load (A)	<b>1167.76</b>			<b>993.96</b>		
$\Delta I_{ph}$ (max - min)	111.44	0.58	6.91	51.90	0.92	12.82
(I <sub>ph</sub> - max) (A)	62.15	0.37	4.20	34.42	0.37	6.14

### Network Training

Neural Function Fitting tool is employed in training the neural architecture in this work. Function fitting is the process of training a neural network on a set of inputs in order to produce an associated set of target outputs. Once the neural network was not trained on

### Limitations of the study

This work is constrained to eighteen (18) different load points as shown in Figure 1. This approach can be extended to any number of unbalanced load data, but at this stage, the work have to be limited to the number of load data exactly divisible by three (3) so that the loads can be equally distributed per phase. This work is also limited to only the reconfiguration o the distribution feeder, and not extended to the phase rearrangement. Network Training. Neural Function Fitting tool is employed in training the neural architecture in this work. Function fitting is the process of training a neural network on a set of inputs in order to produce an associated set of target outputs. Once the neural network was not trained on

## RESULTS

### Simulation Results

The neural network was trained using real data received from the Abuja Electricity Distribution Commission (AEDC) Lokoja Area Office. These data sets had average load current values per consumer in a specific locality of the city for different times of the day. Eighteen clustered consumers within the Lokoja metropolis, whose power consumption data were used to train the neural network, are therefore selected as the case study in this work. The load currents were measured from different transformers and the results are as presented as the various data sets marked as “T1”, “T2” in the Table below. The load parameter indicates the various phases the loads are switched. “I<sub>ph1</sub>” means the respective load is connected to Phase 1; “I<sub>ph2</sub>” to Phase 2 and “I<sub>ph3</sub>” to Phase 3. The switching sequence of the Genetic Algorithm is marked as “GA [Sw]” while that of the Neural Network marked as “NN (Sw)”

Table 3 shows the summary of the results after implementing the both algorithms: artificial neural network and genetic algorithms. The results show the improved GA optimized neural network switching as compared to the Heuristic method’s results. The parameters  $\Delta I_{ph}$  (max - min) and  $\Delta(I_{ph} - I_{max})$  in the table is the maximum difference of the phase currents, which ideally should be zero if there is no imbalances, shows a considerable improvement in balancing when compared to other literatures.

### Neural Network Structure

The back-propagation network has been used for this application. Experimentations with the back propagation and the radial basis network indicated faster training and better convergence for the former. Back-propagation networks may require more neurons than the standard feed forward back propagation networks, but often they can be designed in a fraction of the time needed to train the standard feed-forward networks [5]. They work best when many training vectors are available. MATLAB® neural network toolbox has been used for the implementation

## Training Performance Graphs

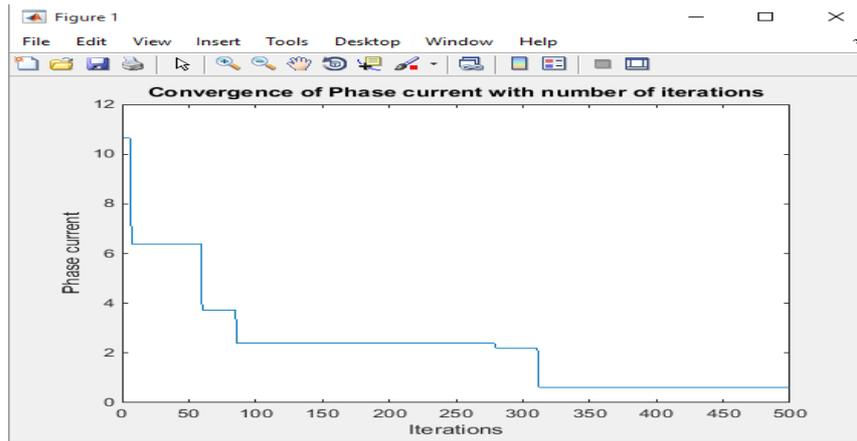

**Figure 5.** Neural Network Training Performance Plot

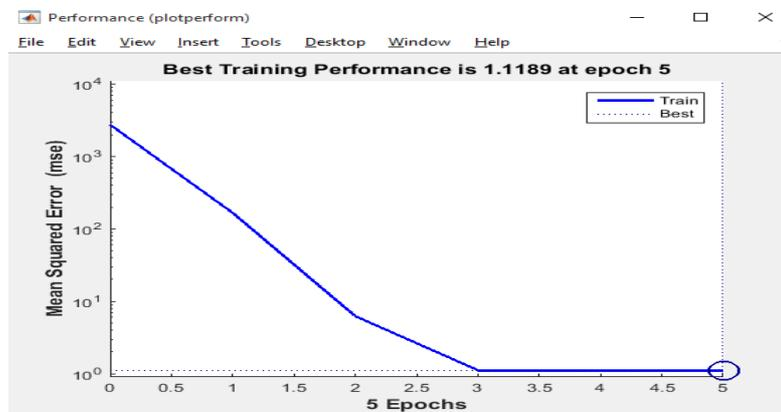

**Figure 6.** Neural Network Training Performance Plot

The GA program was applied to a system of  $Nld = 100$  nodes. The population size was chosen to be  $Nchr = 500$  chromosomes (Figure 5). The system was allowed to run for a maximum of  $NG = 500$  generations or until a certain minima is reached. The crossover is effectuated onto 80% of the population and the mutation is performed on the remaining 20%. Figure 6 shows a typical fitness variation curve against the generation number. The ANN algorithms output are the switching sequence for a balanced network.

## CONCLUSION

Based on the analysis obtained from the result, optimizing the ideal loads distribution of the feeder through genetic algorithms was able to successfully improve the load balancing problem. Therefore, the total power losses of distribution systems was effectively reduced by the proper load distribution which is necessary to achieve load balancing under the certain objective function of the total power loss. Load and phase balancing are important complements to network and feeder reconfiguration to attain a balanced distribution system. To automate a distribution network, these problems have to be continuously solved simultaneously to guarantee optimal performance of a distribution system. This paper work formulated the issues of load balancing cum phase balancing in a specific feeder along a LV feeders as current balancing optimization problems with due consideration for the various constraints. The network and feeder reconfiguration problem are however formulated as power loss minimization problem with the view for its solution to control the opening and closing of tie switches connecting the various load centres to the distribution feeder.

## Contribution

The contribution of this work includes:

- I. Provide a dynamic load balancing operation of three-phase system through continuous metering of individual single-phase loads.
- II. Help to continuously avoid feeder imbalances and power losses in a distribution system.

- III. Provides a platform for the Power Distribution companies to monitor the load current and hence, ensures proper planning of the network.

### Recommendation

One of the objectives of this paper is to investigate the potential of neural network approach in balancing three phase network, so that if required, it could be implemented for critical load areas like industrial loads e.g. three-phase machine etc. by incorporating autonomous controller for three-phase change-over possibilities.

### Assumptions

The following assumptions were made for the techniques and the application examples presented in this paper work.

- i. For the load balancing problem, a three-phase, four-wire, 50Hz LV distribution system with a radial structure is considered in this work.
- ii. Each feeder is assumed to have 6 connections, i.e., 18 total connections at any point of time.
- iii. The threshold average Ideal load is taken as one-third of the total load demand per phase. Over this value, phase balancing is initiated, otherwise not.
- iv. The total load, at any point of time, remains constant, i.e., during the phase balancing, only inter-changing of the load points is possible, not increase or decrease of the total load.

### REFERENCES

- [1] A. A. Jimoh, D. V. Nicolae and M. W. Siti "LV and MV Distribution Networks Reconfiguration for Minimum Losses", Paper accepted for presentation at 2009 IEEE Bucharest Power Tech Conference, June 28th - July 2nd, Bucharest, Romania
- [2] A. Gouda, A. Abul-Farag, H. Mostafa and Y. Gaber "Smart Electric Grids Three-Phase Automatic Load Balancing Applications using Genetic Algorithms"
- [3] T. T. Nguyen and A. V. Truong, "Distribution network reconfiguration for power loss minimization and voltage profile improvement using cuckoo search algorithm," *International Journal of Electrical Power & Energy Systems*, vol. 68, pp. 233-242, 2015
- [4] A. Ukil, M. Siti, J. Jordaan, MATLAB Based Fast Balancing Of Distribution System Using Genetic Method, *IEEE Transactions (Under Review)*.
- [5] A. Ukil, M. W. Siti, D. V. Nicolae, and A. A. Jimoh "Reconfiguration and Load Balancing in the LV and MV Distribution Networks for Optimal Performance", *IEEE Transactions on Power Delivery*, Vol. 22, No. 4, October 2007.
- [6] A. Ukil, W. Siti, J. Jordaan, Feeder Load Balancing Using Neural Network, *Lecture Notes In Computer Science* 3972 (2006) 1311-1316.
- [7] D. V. Nicolae, M. W. Siti and A. A. Jimoh: "LV Self Balancing Distribution Network Reconfiguration for Minimum Losses", Paper Accepted For Presentation at 2009 IEEE Bucharest Power Tech Conference, Bucharest, Romania.
- [8] Hassan Fathabadi, "Power Distribution Network Reconfiguration For Power Loss Minimization Using Novel Dynamic Fuzzy C-Means (DFCM) Clustering Based ANN Approach", *International Journal of Electrical Power & Energy Systems*, Vol. 78, Pp. 96, 2016.
- [9] Hye Ji Kim & Yong Tae Yoon. Reconfiguration For Load Balancing of Feeder in Distribution System Including Distributed Generation. *Journal of International Council on Electrical Engineering*
- [10] M. Siti, A.A Jimoh and D. Nicolae " Load Balancing in distribution feeder Through Reconfiguration" *IECON05*, Raleigh, North Caroline, 6- 12 Nov. 2005
- [11] Maurizio Delfanti, Davide Falabretti, Marco Merlo, Diana Moneta, "Networks Reconfiguration for Losses Reduction", *Energy Conference & Exhibition (Energycon) 2012 IEEE International*, Pp. 318, 2012.
- [12] Abanihi, V. K., Ezomo, P. I., Aliu, D., Chinedu, P. U., Obari, J. A., & Momoh, M. O. (2020). "Complementarity Problem Approach to Economic Power Dispatch of Nigeria Power System". *ATBU Journal of Science, Technology and Education*, 8(2), 240-249, June 2020
- [13] Abubakre, O.R., Ubadike, O., Aibinu, A.M., Folorunso, T.A., & Momoh, M.O. (2021). Artificial Neural Network Embedded Optimal Communication System. *Covenant Journal of Informatics and Communication Technology*, 9(2). December, 2021