

ORIGINAL ARTICLE

# Torque analysis of a platform based end effector ankle-foot orthosis for rehabilitation

Abdul Haleem Habeeb Mohamed and Muhammad Aizzat Zakaria\*

Faculty of Manufacturing Engineering, Universiti Malaysia Pahang, 26600 Pahang, Malaysia.

**ABSTRACT** – This paper presents the control of a one degree of freedom for lower limb platform based end effector ankle foot orthosis for rehabilitation. The plant of the system is obtained through system identification approach and a proportional-integral (PI) architecture is employed to investigate its efficacy in performing joint-space control objectives namely the dorsi-plantar flexion of the ankle joint. It was demonstrated from the study that the PI performed well against the torque control parameter for the system.

## ARTICLE HISTORY

Received: 1 September 2018

Revised: 21 December 2018

Accepted: 3 January 2019

## KEYWORDS

rehabilitation  
ankle-foot orthosis  
proportional-integral control

## Introduction

The lower leg joint contributes most to strolling in contrast with other repetitive joints of a leg, because of its high torque it is inclined to damage. Consistently a huge number of individuals experience the ill effects of lower leg joint hindrances, typically identified with shortcoming because of maturing and ailments, for example, polio, stroke, cerebral paralysis and different sclerosis. Last time, the main option for influenced individuals was a mobile stick or a wheelchair and as of late assistive automated orthoses have been created to enhance the life of such people. Ankle-foot orthoses can be partitioned into two classifications which are a passive device, more often than not props that keep the foot from achieving certain positions and active AFOs that contain an actuator controlled in a way to help amid walking. [1]

In a population of elderly people with low birth rate, many of them suffering from injuries or sickness that needs a longer period of time to for rehab and to heal [2]. Data according to World Health Organization (WHO) people over 60 years has high chances of being attack by stroke, and the number of elderly people is believed to increase by half from 11% to 22% in 2050. The statistic shows that 54% elderly people are from Asia, 22% in Europe and 24% from other country [3]. Stroke is the cause of impaired motor function and still much patient loss the ability or have limited ability to lift their foot after undergoing rehabilitation process this and this syndrome is known as foot drop.

Legs are imperative parts that play an important role for walking which encourages strolling

development starting with one place then onto the next. However, the capacity to walk regularly might be disturbed by neurological confusion caused by spinal cord damage, stroke and injury. Ankle Foot Orthosis (AFO) is a rehabilitation device that is to rehabilitate strolling step to stimulate the muscle developments to re-establish its quality. The patients are required to make rehashed leg developments. Customarily, this errand is directed by a physiotherapist who encourages the patients in making rehashed developments with the progression of innovation [4].

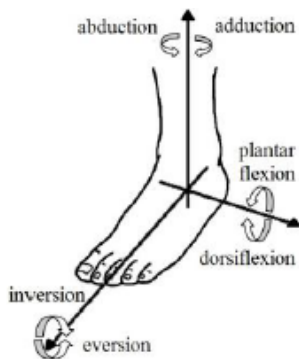
The ankle joint is an exceptionally complex hard structure in the human skeleton and assumes a significant part in keeping up body adjust amid ambulation. Actually, the ankle is the most well-known site of sprain wounds in the human body. In any case, the greatest impact on patients with ankle inabilities and their relatives is typically an aftereffect of long haul hindrance, the constraint of exercises and decreased investment [5].

These days, there are three sorts of activities utilized as a part of restoration forms which is passive, assisted and active. In passive activities, the nurse or physiotherapy moves the joint without the patient's muscles input. Next is a medium mode which is the assisted work out that joins the endeavours of patient and physiotherapy. Active recovery is full intentional exercise movement that is performed by the individual himself, with or without protection. There has been extensive enthusiasm for creating recovery devices by innovation advancement organizations, establishments and colleges around the globe to completely restore the influenced part for example knee, ankle, hands amongst others [6].

## Methodology

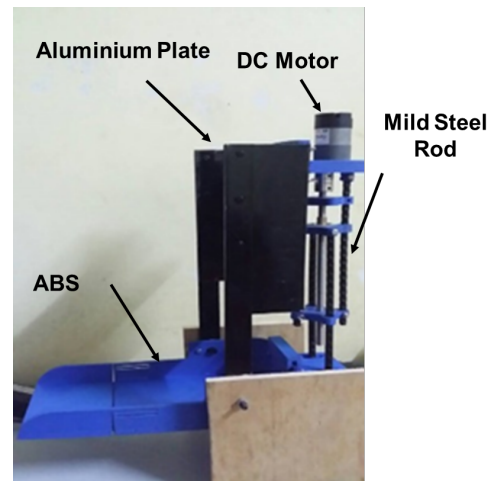
### Prototype Design and Development

Ankle rehabilitation system is a combination of two systems that act as ankle rehabilitation and foot exerciser. This system can be used in general as an exercise device and not limited to patients only. There are three basic movements in the ankle-foot: dorsiflexion-plantar flexion, inversion-eversion and abduction-adduction as shown in Figure 1. The concept of the proposed ankle rehabilitation device is expected to focus on the dorsiflexion-plantar flexion motion.



**Figure 1.** Movement of foot ankle [7].

Ankle rehabilitation system principle is developed to be user-friendly where the device is easy to carry anywhere, adjustable according to user comfort and safety. The system development consists of hardware and software design. For the prototype of this device, it is mostly where made of Acrylonitrile butadiene styrene (ABS), and aluminium plate and mild steel rod.

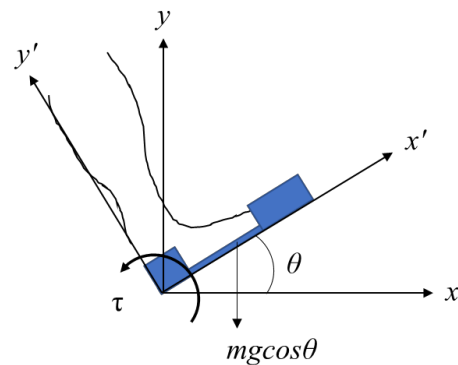


**Figure 3.** A prototype of Platform-Based End Effector Ankle Foot Orthosis for Rehabilitation.

As shown in Figure 3, it is the assembled parts of the device which unable to make a dorsiflexion-plantar flexion. Moreover, the device is using an actuator which is the encoded DC motor where it is connected with a linear shaft to form a linear movement and as the motor is rotating it will create an up-down movement to the ankle foot.

### Dynamic Modelling

The Lagrangian is employed to obtain the torque,  $\tau$  of the system as shown in Equation 1.



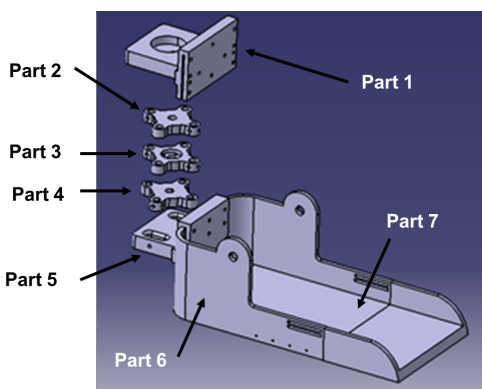
**Figure 4.** Free body diagram of the system.

$$\tau = ml \ddot{\theta} + mgl \cos \theta \tag{1}$$

where  $m$  is the mass,  $l$  is the foot length,  $g$  is the gravitation constant with a value of  $9.81 \text{ m/s}^2$ , whilst the angular motion and angular acceleration are denoted  $\theta$  and  $\ddot{\theta}$ , respectively.

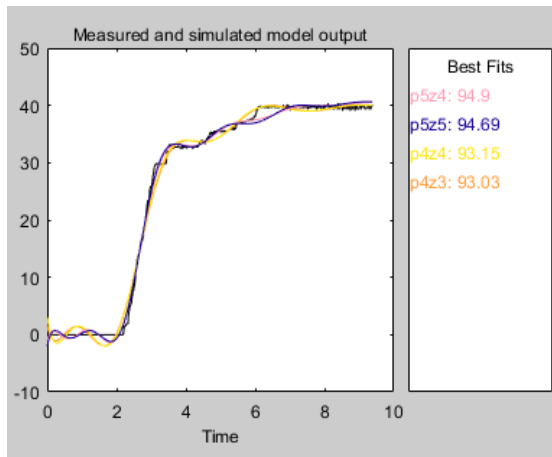
### System identification

MATLAB & Simulink software is used to control and refine the system design and eliminate errors before developing hardware prototypes. A simulation investigation is performed to identify the suitable controller for the system. The potentiometer is using

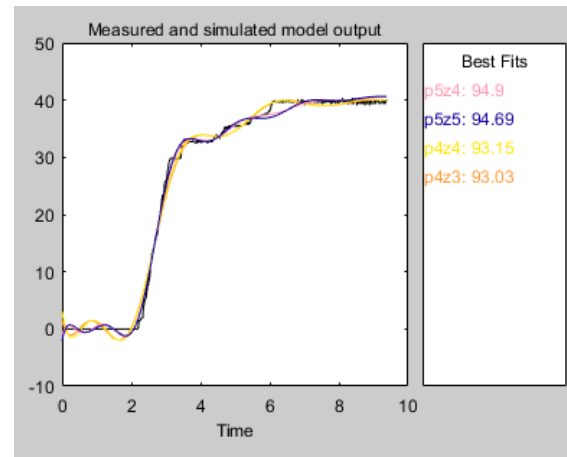


**Figure 2.** Parts made of ABS using 3D printer.

As shown in Figure 2, there are seven parts that were made using the 3D printer as it is easier to design using CATIA and to get the desired shape of the parts with the accuracy of  $\pm 0.5 \text{ mm}$ .



**Figure 5.** Measured and simulated model (estimation).



**Figure 6.** Measured and simulated model (validation).

to the measured output signal from the rotation of the motor whilst the current sensor is using to acquire the input signal. MATLAB System Identification Toolbox (SI) is used to ascertain the model of the system based on the recorded input-output measurements.

Besides that, an L298N Module Dual H-Bridge motor driver is used to control the direction and pulse width modulation (PWM) of the DC motor. The value of the current flow is recorded through the current sensor (BB-ACS756) to use as the input measurement. The value of angular displacement is recorded through potentiometer will be the output measurement. Arduino Mega 2560 will take part as the data acquisition device.

The MATLAB System Identification Toolbox, the plant of the system, is obtained by analysing the input-output measurement system, in which a set of the continuous transfer function is applied to identify the suitable classical control configuration in estimation and validation mode. The computation can be made from the continuous transfer function in a mathematical model and simulation model. This is because the limitation of the system and disturbance make the transfer function show the different response. After the suitable model is identified, simulation is performed via MATLAB Simulink to investigate the best classical control configuration to achieve the desired steady-state error for the system, and the performance of the system is evaluated.

## Results and discussion

The best fit of the data measurement could be examined in Figure 5 (estimation) and Figure 6 (validation), that the continuous transfer function (5p4z) model fits well in both the estimation (94.9%) and validation (86.34%) stage. The (4p3z) transfer function equation (Equation 2) is as follows:

$$\frac{\emptyset m(s)}{Ea(s)} = \frac{-4.98s^3 + 22.67s^2 - 50.03s + 44.13}{s^4 + 2.751s^3 + 7.97s^2 + 10.68s + 4.993} \quad (2)$$

Figure 7 depicts the Simulink block of the system, whilst Figure 8 illustrates the performance of the control schemes evaluated. Meanwhile, PI controller is selected over PID controller as shown in Table 1, where the rise time, settling time and percentage overshoot is almost similar. As shown in Figure 8, the graph shows the different controller, and for the PID controller, the value of D (derivative) is equal to zero which it is considered as a PI controller.

**Table 1.** Performance analysis.

Controller	Rise Time (s)	Settling Time (s)	Overshoot (%)
P	2.16	25.60	78.0
PI	3.94	8.21	0.0
PD	2.16	25.70	78.2
PID	4.36	9.28	0.0

## Conclusion

In this study, the identification and control of a platform based end effector ankle-foot orthosis for the rehabilitation of dorsiflexion-plantar of the ankle joint were carried out. The transfer function of the ankle device was successfully identified. Simulation and hardware implementation was carried out to get appropriate controller gains by using torque control. For future study, it is recommended to choose a suitable actuator and using machine learning for the controller.

## References

- [1] M. N. A. Ab Patar, A. F. Said, J. Mahmud, A. P. P. Abdul Majeed, and M. A. Razman, "System integration and control of Dynamic Ankle Foot Orthosis for lower limb rehabilitation," in *ISTMET 2014 - 1st International*

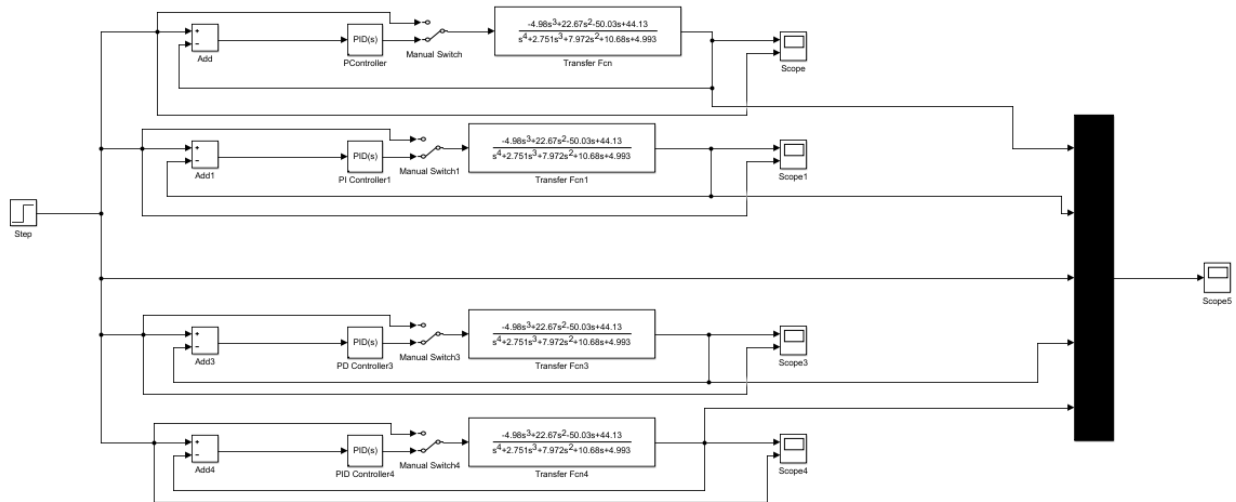


Figure 7. Simulink model of the system.

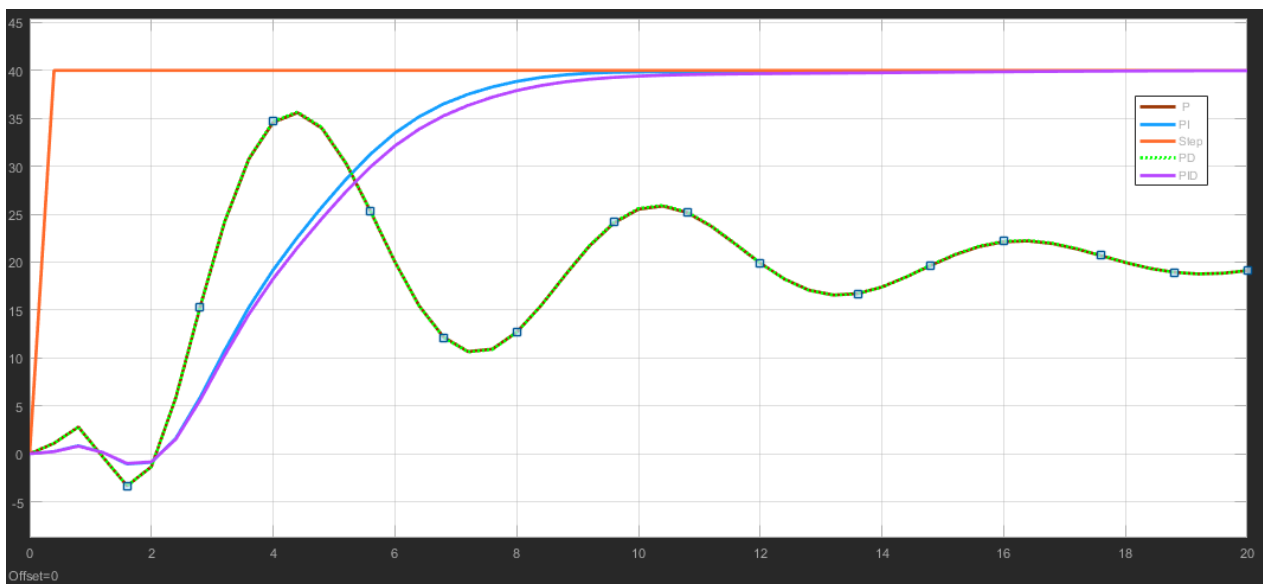


Figure 8. Performance of the evaluated control schemes.

*Symposium on Technology Management and Emerging Technologies, Proceedings*, 2014.

[2] A. Patar, N. Jamlus, K. Makhtar, J. Mahmud, and T. Komeda, "Development of dynamic ankle foot orthosis for therapeutic application," in *Procedia Engineering*, 2012.

[3] C. Loconsole, S. Dettori, A. Frisoli, C. A. Avizzano, and M. Bergamasco, "An EMG-based approach for on-line predicted torque control in robotic-assisted rehabilitation," in *IEEE Haptics Symposium, HAPTICS*, 2014.

[4] T. Seel, C. Werner, and T. Schauer, "The adaptive drop foot stimulator – Multivariable learning control of foot pitch and roll motion in paretic gait," *Med. Eng. Phys.*, 2016.

[5] A. Hamid, M. N. A. A. Patar, and M. A. Ayub, "Force sensor detection and performance evaluation of new active system ankle foot orthosis," in *Procedia Engineering*, 2012.

[6] M. Zhang, T. C. Davies, and S. Xie, "Effectiveness of robot-assisted therapy on ankle rehabilitation - A systematic review," *Journal of NeuroEngineering and Rehabilitation*, 2013.

[7] A. B. Ortega, E. Q. M'rmol, G. V Valdés, G. L. López, and H. R. A. Rivera, "Control of a Virtual Prototype for Ankle Rehabilitation," in *2012 Eighth International Conference on Intelligent Environments*, 2012, pp. 80–86.