

Fuel consumption evaluation of SI engine using start-stop technology

M.A. Abas^{1*}, W.S. Wan Salim², M.I. Ismail³, S. Rajoo¹ and R. Martinez-Botas³

¹Low Carbon Transport Research Centre, Universiti Teknologi Malaysia
81310 Johor Bahru, Johor, Malaysia

* Email: azman.abas@utm.my

Phone: +6075534853; Fax: +6075566159

²Universiti Tun Hussein Onn Malaysia

86400 Parit Raja, Johor, Malaysia

³Imperial College London

Kensington, London SW7 2AZ, United Kingdom

ABSTRACT

The engine start-stop technology is gaining acceptance as a key technology adopted by manufacturers to improve the fuel economy of passenger cars. This technology shuts the engine off when a vehicle is at a stop. The inherent issue with the implementation of the start-stop technology in hot climates is the requirement for the air-conditioning system to be in constant operation which reduces the duration of engine shut-off during vehicle stops, and consequently, nullifying the benefit of the system. The aim of this study is to evaluate the potential fuel consumption improvements on a spark ignition engine when using the start-stop technology in real conditions of the Malaysian tropical climate, with consideration towards cabin comfort temperature. The result provides useful insight and enables vehicle manufacturers to assess whether such technology is feasible for implementation in tropical climates. A 1.6 litre spark ignition engine was modelled along with an air-conditioning system model using a commercial one-dimensional engine simulation gas dynamic software. A vehicle driving profile of engine speed and engine torque obtained from real driving on Malaysian roads was captured and used as the boundary conditions for the simulation. Iterations of the start-stop strategy were simulated to further explore the possible impacts on fuel consumption. The result of this study showed that the duration of engine shut-off during vehicle stops becomes shorter due to the necessity of the air-conditioning system to operate in maintaining the cabin's comfort temperature. With the shorter duration of engine shut-off, the fuel consumption improvement stemming from the start-stop technology is reduced from the average of 20.7 % to 11.0 %, therefore, addressing the concerns on the application of the start-stop technology in hot climate countries and the opportunity to further optimise fuel consumption.

Keywords: Engine; start-stop; fuel consumption; air-conditioning; real driving.

INTRODUCTION

Recently in September 2017, Europe had implemented both the WLTP (World-wide Harmonised Light Duty Vehicles Test Procedure) and the RDE (Real-Driving Emissions) as replacements for the NEDC (New European Driving Cycle) procedure to measure light-duty vehicles' exhaust pollutants and CO₂ in complying with the European Union's

Euro 6 limits [1]. The WLTP and RDE were developed to be more accurate and realistic in representing real driving and a broader range of conditions. Adaptation of the stringent WLTP and RDE as part of the legislation and vehicle requirements has already been seen in many countries across the globe [2, 3]. This step will force significant emission reductions in the real world as these rules force manufacturers to further develop more highly-efficient road vehicles in complying with the stringent legislation requirements. Nevertheless, efforts have already been made to improve vehicles' emission levels and fuel economy in many aspects through engine key technologies, engine operating conditions and engine designs that are developed to behave accordingly during real driving conditions [4]. In real driving conditions, be it urban, rural or motorway, a passenger car's engine mostly operates under part load conditions. Engines are more likely to operate at lower engine speeds with lower engine load in traffic. Moreover, passenger cars tend to spend considerable time in an idle position, especially when in congested traffic. Traffic congestion is a well-known reality of life in urban areas and a common issue faced by developing countries [5] such as Malaysia. The increase in the number of vehicles on the road is one of the main causes of lower average traffic speeds below the existing speed limits. Vehicles travelling in highly congested traffic areas are expected to encounter regular and longer stops, whereas vehicles travelling in mild traffic move at medium acceleration and speed for a short period before coming to a halt. Therefore, manufacturers have adopted key technologies and optimised engine operations to improve fuel consumption for both the regularly visited engine part load condition and idling conditions. As such, the start-stop technology was introduced to improve fuel consumption during vehicle stops and is especially meant for vehicles that are regularly at idle in congested traffic. This technology allows the engine to be shut-off automatically when the vehicle is stopped and the engine is at idle, thereby, saving unnecessary burning of fuel. Studies on the start-stop technology have been conducted widely to maximise fuel consumption and meet legislation guidelines, and more importantly for consumers' fuel economy. Most of the fuel consumption studies conducted on start-stop technology were applied on drive cycles of vehicles from the United States, Europe and Japan. Fuel consumption benefits were found to improve within the range of 2.8-35.0 % depending on the technology, method and vehicle used [6-9]. Hypothetically, the amount of fuel consumption benefit from a start-stop is proportional to the amount of time the engine spends in the stop-mode [10]. Higher engine stop-mode durations maximise the fuel consumption benefit from the technology, which is why the start-stop technology benefits vehicles that are driven in congested traffic areas [4].

However, one of the concerns related to the start-stop technology is the ability to maximise the fuel consumption benefit in hot climates. High ambient temperatures in hot tropical climate countries such as Malaysia cause the need for the air-conditioning system to operate to ensure that the temperature in the cabin room is within demand. According to the Malaysian Meteorological Department, Malaysia's climate is generally characterised as having uniform temperature, high humidity and many rainfalls. Its average temperature is 28.6 °C with the largest deviation of 1.7 °C recorded in the month of February 2014. The mean maximum temperature recorded is 35.6 °C and the highest temperature recorded was 37.0 °C. With such high ambient temperatures, the air-conditioning system of a vehicle is expected to be constantly operating to maintain the cabin's comfort temperature. With the start-stop technology, the engine is expected to go into the stop-mode during vehicle stops which in turn will cause the air-conditioning compressor to stop pumping and circulating the refrigerant in the system, thus, prevent the heat exchange process to take place. As a consequence, the cabin temperature will rise

over time. A conventional air-conditioning system works by controlling the engagement of the clutch on the compressor pulley. The temperature control is strategized to meet the designated temperature based on the input signal from the thermistor temperature sensor located at the evaporator. For an engine with the start-stop system, when the cabin comfort temperature reaches the designated limit, the engine is required to restart for the compressor to circulate the refrigerant. High increases in cabin temperature require the engine to start earlier and as a result, shortens the duration of the engine's stop-mode, thus, reduces the fuel consumption benefit. Therefore, the objective of this paper is to evaluate the fuel consumption benefit of the start-stop technology in a spark ignition engine passenger car used under the Malaysian tropical climate conditions. This paper describes the behaviour of the start-stop strategy according to the demand which is to sustain the cabin's comfort temperature, and quantifies the fuel consumption benefit of vehicles driven in the Malaysian tropical climate. Information acquired from this study will be beneficial for start-stop technology applications and the development of vehicles that are strategized for countries with hot climates.

METHODS AND MATERIALS

This study used the vehicle and engine variables collected from real driving experience in Malaysia which was conducted in a previous study by the authors in [11] as the boundary conditions for the simulation in this study. The air-conditioning and cabin comfort operations were then conducted in this study to assist the fuel consumption analysis using the start-stop system. The collected data were used to calculate the vehicle fuel economy and engine fuel consumption with the application of the start-stop system. The collected data were also used for simulation using a commercial one-dimensional engine simulation software to predict the expected engine fuel consumption and vehicle fuel economy improvements that could be achieved during real driving in the Malaysian tropical climate.

Experimental Setup

The fuel consumption data from an instrumented 1.6 litre passenger car with specifications shown in Table 1 derived from an experiment conducted in Malaysian real driving conditions were obtained from a previous study [11]. All data variables from the ECU such as vehicle speed, engine torque and engine speed were recorded during the real driving experiment using an accessible ECU via communication tools and software provided by OEM. Considering many driving aspects such as traffic congestion, short drive stints and highway driving, a single route from the previous study was selected as the boundary condition for the one-dimensional simulation in this study. The selected route as shown in Figure 1 comprised of a 1,400 s long drive with several stops, making it suitable for the start-stop system application. A microtrip method used by [12] was then applied on the real-driving data of the selected route to statistically analyse the stop durations. Microtrip is a method that splits a vehicle's speed data into smaller trip sequences. A microtrip consists of a vehicle's speed profile taken between two consecutive stops. The sequence starts from a vehicle's previous stop, and ends the instant the vehicle's speed falls to zero. These sequences are then characterised using variables such as vehicle speed, idling time, distance, duration and others.

Table 1. Vehicle specification.

Subject	Specification
Vehicle type	Passenger car, 4-doors
Curb weight	1,300 kg
Transmission	CVT
Engine	1.6L, 4-cylinder inline, PFI engine

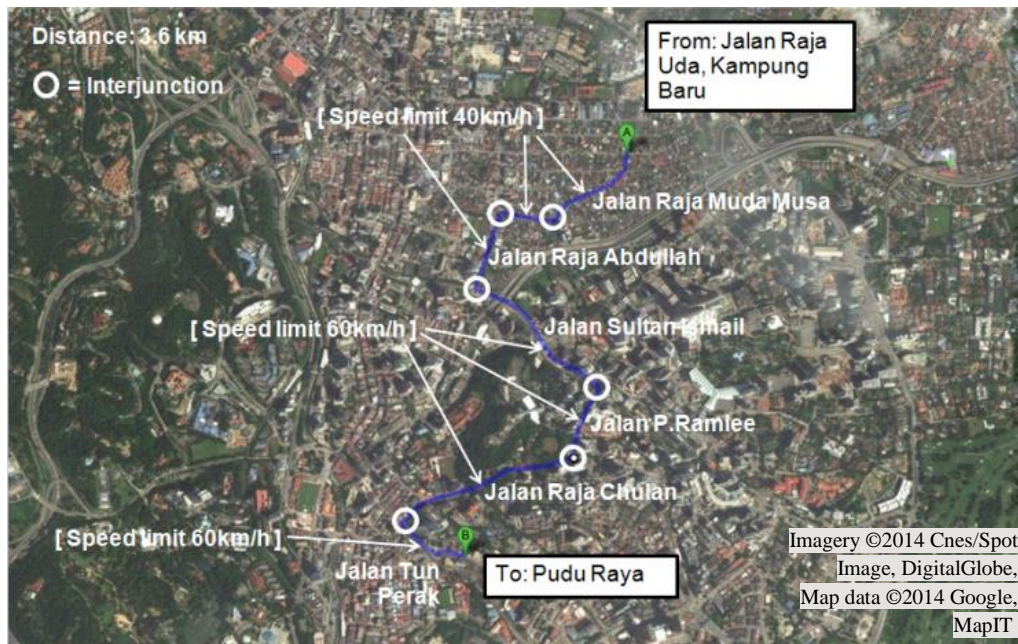

Figure 1. The selected route in Kuala Lumpur.

A study on cabin comfort temperature was also conducted on the vehicle to understand the duration for the air-conditioning system to activate and deactivate the compressor during idle conditions at midday. The vehicle was instrumented with thermocouples which were positioned at the air-conditioning ventilations and a thermistor to record the operating temperatures. A voltage signal at the compressor was also used to capture the compressor’s deactivation and activation behaviour.

One-Dimensional Simulation

As part of this investigation, a one-dimensional transient engine performance simulation was conducted to assess the fuel consumption of an engine operated over a selected route, and the potential fuel savings that can be obtained through a start-stop mechanism. The 1.6 litre spark ignition engine of the vehicle was modelled as shown in Figure 2, and the baseline performance was validated with dynamometer measurements. The engine torque demand recorded during the real driving experiment was used as the transient profile input along with the corresponding engine speed as shown in Figure 3. The throttle model was controlled via a PID controller element such that the engine meets the required torque demand. An air-conditioning model was coupled to the engine by means of a counter-torque element, which means that part of the total engine torque output is used to drive the air-conditioning compressor. Here, it was assumed that the air-conditioning compressor is constantly driven by the engine whenever it is running. The simulation was iterated for four cases as shown in Table 2. The cases were labelled as 0, A, B, C and D.

Case 0, which is the dyno-validated engine model, represents the baseline engine without the start-stop system and the air-conditioning. Case A represents the baseline model of the engine with the start stop system, but without air-conditioning. Cases B, C and D represent the engine with air-conditioning and start-stop systems that differ in terms of the engine start-mode timing strategy. For Case B, the engine immediately stops once it senses that the torque demand is at zero, and immediately restarts once torque is demanded. Cases C and D, on the other hand, are cases where the engine is restarted after a period of three and five seconds respectively, regardless of the torque demand still being at zero. This is to demonstrate the need for the engine to restart when the cabin temperature is sensed to be higher than the pre-set limit to allow for the air-conditioning compressor to operate. The cycle average fuel consumption normalised by the maximum value for the baseline model (Case 0) was reported for the selected route using the real driving profiles with the engine speed versus torque depicted in Figure 3.

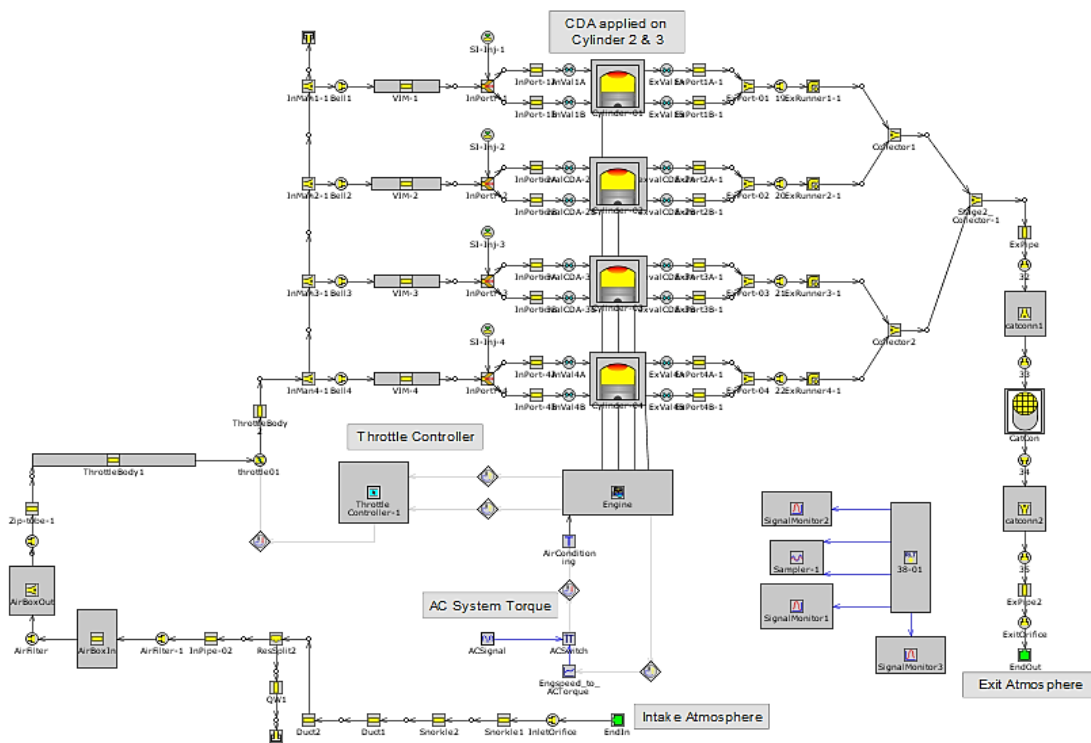

Figure 2. One-dimensional engine model.

Table 2. Simulation cases.

Case	Description
0	Baseline
A	Baseline + start-stop
B	Baseline engine + air-conditioning + start-stop (0 s delay)
C	Baseline engine + air-conditioning + start-stop (3 s delay)
D	Baseline engine + air-conditioning + start-stop (5 s delay)

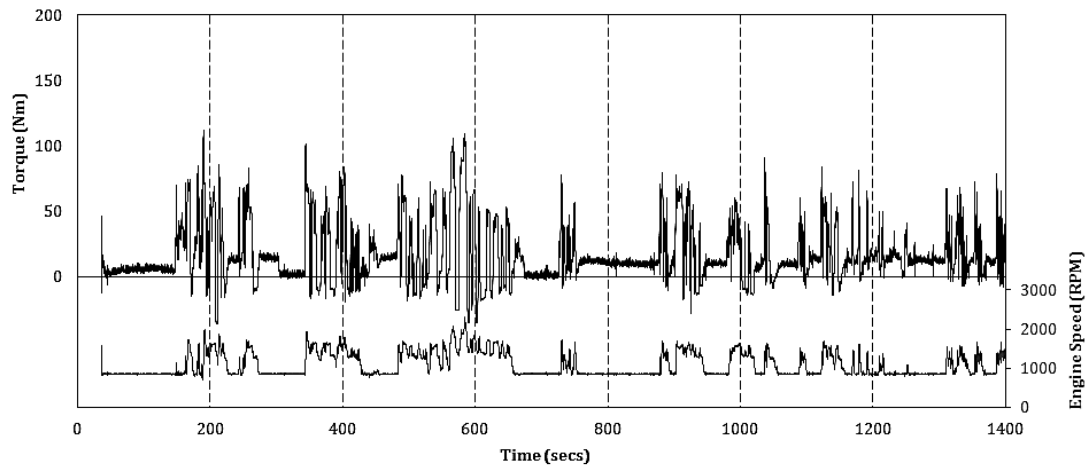

Figure 3. Engine torque and engine speed profiles used in the one-dimensional simulation.

RESULTS AND DISCUSSION

Referring to a previous study conducted by the author in [11], the total cycle of data which consist of five congested routes during peak hours were statistically analysed in this study. The distribution of vehicle speeds was plotted into a histogram chart as shown in Figure 4. The idle condition had the highest frequency of 35.7 % compared to other speeds with a mean of 17.56 and standard deviation of 23.75. The distribution was seen to be bound at lower speeds, but had reached a maximum speed of 100 km/h. This explains that vehicles travelling along the route tend to spend a considerable amount of time at idle for a trip with travelling speeds below 60 km/h, thus, can be classified as congested urban traffic. Like the speed categories in the WLTP, travelling speeds below 60 km/h with an average of 15-40 km/h are classified under the urban specification [13]. The typical time a vehicle spends on the road at idle in Malaysian real driving is therefore understood, and the potential of the start-stop technology seems relevant and beneficial.

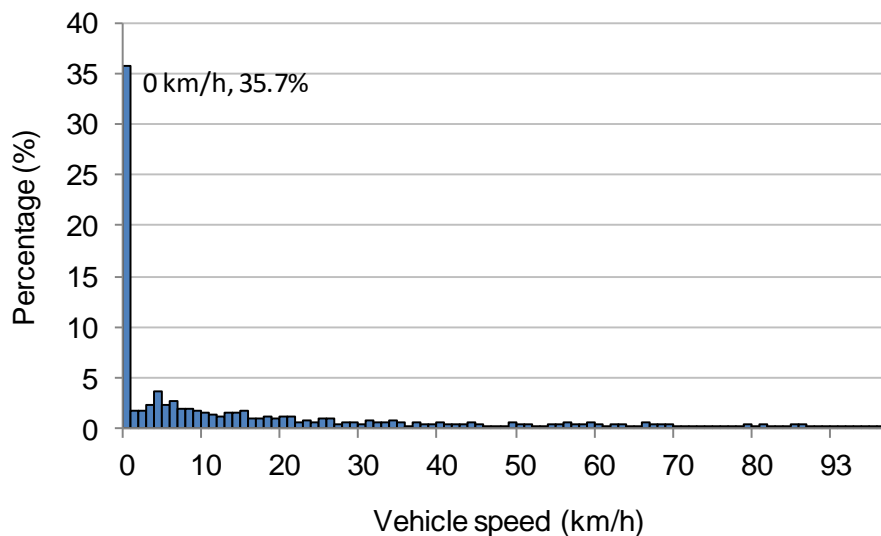

Figure 4. Histogram of vehicle speed.

Furthermore, to understand the vehicle's fuel economy impact, the fuel that was consumed during idle conditions was excluded from the total amount of fuel being used in the five routes without considering any other factors, as shown in Figure 5. The amount of improvement was seen to be affected by the stop duration. The contribution of fuel consumption from the idle condition was apparent in heavier traffic congestion as characterised by the higher stop duration as shown in routes No.2 and No.4. By having the start-stop technology, the engine automatically shuts-off, and no fuel is expected to be consumed during this period. Based on the total stop duration derived from the real driving experiment conducted in this study, the maximum benefit gained in terms of fuel economy improvement from the start-stop technology for each route by an average vehicle without considering other cabin comfort requirements was 21.8 %.

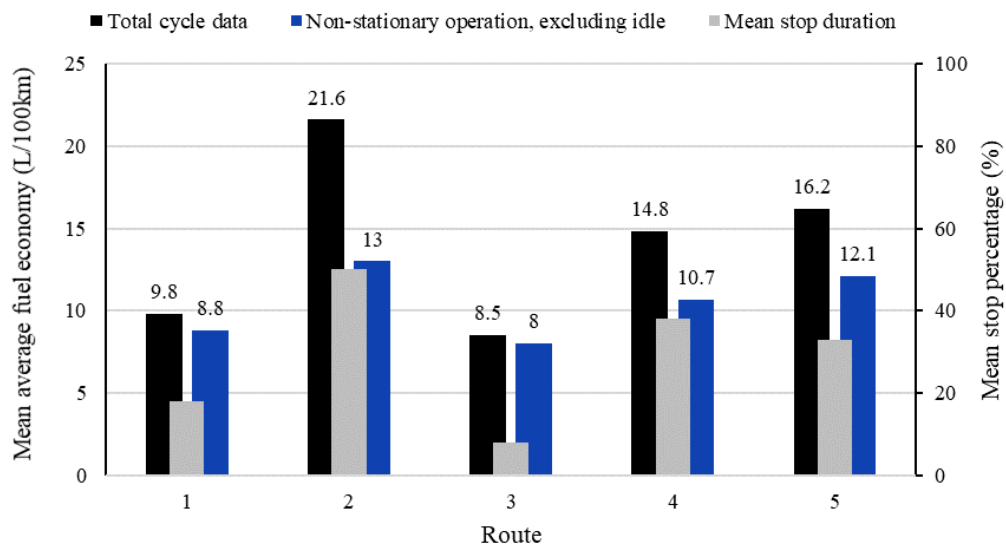

Figure 5. Comparison of average fuel economy (L/100km) between total cycle data and non-stationary operations.

However, this study did consider the cabin comfort temperature requirement of a typical passenger car in Malaysia into the fuel consumption analysis under the start-stop technology. Cabin comfort temperature may vary depending on the type and segment of the vehicle. The cabin comfort temperature used in this study may not represent the entire vehicle segment but nevertheless, provides a trend and an indicator of how cabin comfort temperature may behave in a hot climate. Temperature measurements on the air-conditioning operation in a vehicle during idle conditions were conducted at midday with an average ambient temperature of 34.7 °C. The strategy of the air-conditioning system in the vehicle was observed and measured to regulate the cabin comfort temperature to 16 °C, which was the coldest demand. The cabin comfort temperature was achieved by the air-conditioning system through the temperature regulation of the thermistor sensor at the evaporator within the range of 1-8 °C which brings to the activation and deactivation of the compressor. The voltage signal at the compressor was recorded to identify the activation and deactivation of the compressor as shown in Figure 6. As the thermistor temperature reaches its designated limit, the air-conditioning system cuts off the signal to the compressor and thus deactivates the clutch for an average duration of 7.3 s. During the deactivation, the temperature of the thermistor and cabin rises due to the hot ambient temperature outside the vehicle. With higher ambient temperatures, the increase

of cabin comfort temperature is expected to be higher, and vice versa. As the temperature increases beyond the air-conditioning temperature designated limits, the system reconnects the signal to the compressor and activates the clutch for an average duration of 11.8 s. As the compressor is belt-driven by the engine, the average time also indicates how long the start-stop system shuts the engine before restarting. The deactivation and activation time recorded in this study was used in the fuel consumption analysis and simulation as a requirement for the engine to restart during idle conditions.

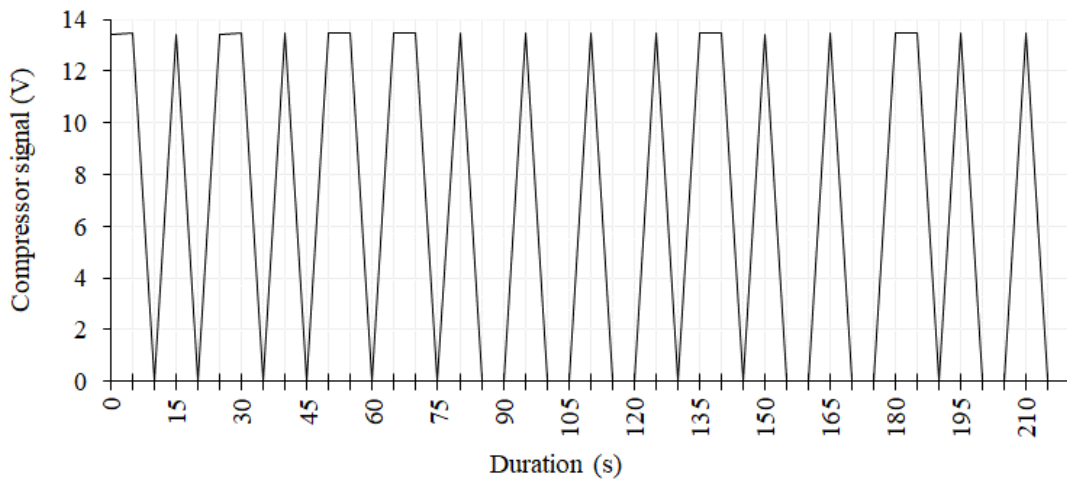

Figure 6. Compressor activation and deactivation during idle conditions.

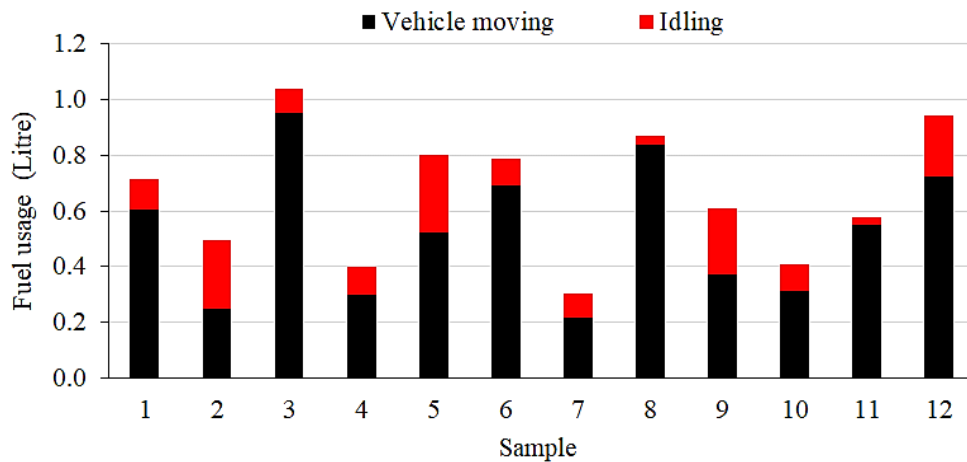

Figure 7. Comparison of fuel usage between moving and idling vehicles.

Twelve random samples among the five routes were used to analyse the fuel consumption by the engine. These samples are the repetition of tests taken during the data collection for the five routes. The average fuel usage during idle conditions alone was calculated to be 1.02 kg/h. With no fuel being used whenever the start-stop system shuts the engine, a calculation was made by removing the fuel consumed by the engine during idling from the samples. With the fuel usage during idle separated from the total fuel usage, the maximum amount of fuel usage that can possibly be reduced was identified as shown in Figure 7. The amount of fuel saving varied but had managed to reach up to 52.4 % depending on the number of stops and the duration of each stop, with an average fuel saving of 20.7 %. However, the above calculation did not consider the limitation of the

air-conditioning system discussed earlier. To ensure that the cabin comfort temperature of the studied vehicle is met, the compressor is required to be turned on for 11.8 s following the engine’s shut-down for a duration of 7.3 s. Each vehicle stop is unique in terms of duration, hence, the duration of stops for each microtrip was considered as shown in Figure 8. The microtrips were statistically clustered using the *TwoStep* technique by SPSS which consists of two steps in which the first step preliminarily clusters the cases into small sub-clusters using the sequential approach. Based on the distance criterion, each of the data is either merged with a previously formed cluster or forms a new cluster. The second step involves clustering the sub-clusters produced from the first step until the desired number of clusters is achieved using hierarchical algorithm. To measure the distance between clusters, the Euclidean distance as expressed in Equation 1 was used for this study.

$$D_{ij} = \sqrt{\sum_{k=1}^n (x_{ki} - x_{kj})^2} \tag{1}$$

where, D_{ij} is the distance between cases i and j ; x_{ki} value of variable X_k for case j

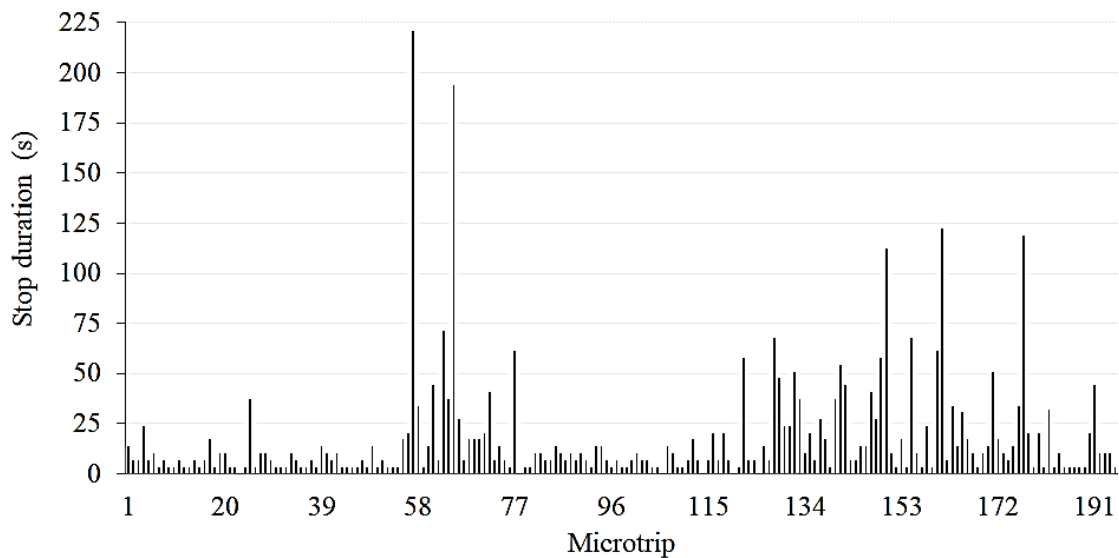

Figure 8. Stop duration of the microtrips.

To automatically determine the optimal number of clusters for the analysis, indicator BIC (Schwarz's Bayesian Information Criterion) was used. For J clusters, indicator BIC was computed according to Equation 2 as follows:

$$BIC(J) = -2 \sum_{j=1}^J \epsilon_j + m_j \cdot \log(N) \tag{2}$$

where:

$$m_j = J \left\{ 2K^A + \sum_{k=1}^{K^B} (L_k - 1) \right\} \tag{3}$$

whereby, K^A is the total number of continuous variables; K^B is the total number of categorical variables; L_k is the total number of categories for the k -th categorical variable.

The *TwoStep* technique naturally produced two main clusters with means of 13.99 s which represented 97.2 % of the samples and 153.72 s which represented 2.6 % of the

samples. The clustering result shows that the mean cluster of 13.99 s was the dominant one, thus was used to represent the stop duration. On the other hand, the total number of sequences produced an average stop duration of 17.74 s.

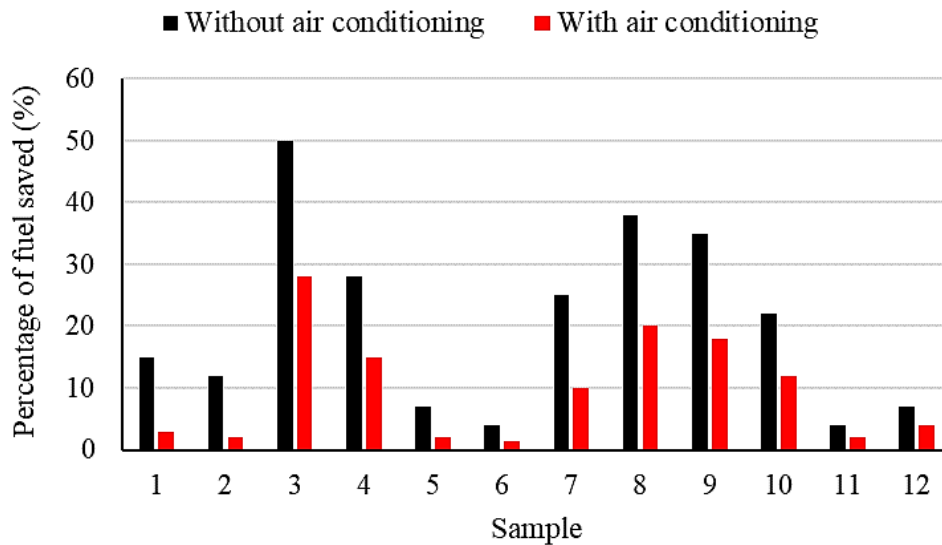

Figure 9. Comparison of fuel saved with activation of air-conditioning system.

Fuel consumption during vehicle stops with consideration of the limitations on the air-conditioning system in each microtrip was calculated. The sum of fuel consumption from each sequence represents the total fuel consumption of the respective sample. Figure 9 shows the percentage of fuel saved between with and without air-conditioning system considerations. The percentages of fuel saved from all samples were seen to drop significantly, ranging between 2.5-21.2 % with a standard deviation of 6.0 % and an average of 11.0 %. In essence, the start-stop technology does improve fuel consumption, but the amount of fuel consumption saved is reduced due to the shortened engine shut-off mode. As discussed earlier, the duration of engine shut off during the vehicle's stop is shorter due to the necessity of maintaining the cabin comfort temperature which had resulted in higher fuel consumption compared to the analysis without the air-conditioning consideration [14]. Analysis of fuel consumption using a one-dimensional analysis was conducted for route No.5. Figure 10 shows the cumulative fuel usage over time along the route, superimposed with vehicle speed. Improvements in terms of fuel consumption are seen to be substantial between Case 0 (baseline) and Case A (baseline + start-stop), which clearly demonstrates the benefit of the start-stop system. The frequent number of stops and large periods of idling time further elevate the benefit of the system. The simulation yield $\approx 50\%$ reduction of cycle fuel consumption when start-stop was implemented. Cases B, C and D involved simulation of engines equipped with air-conditioning together with the start-stop activation. As seen in Figure 10, the presence of the air-conditioning system increased fuel consumption with the amount being almost close to that improved by the start-stop system. This depends on the amount of power drawn from the engine by the air-conditioning compressor and the efficiency of the belting system. It is evident from Figure 10 that varying the engine's re-start timing did not have a significant impact on fuel consumption over the chosen route. The cycle average fuel consumption between the three cases comprising air-conditioning systems varied only slightly between each other by less than 4 %. Signs of fuel saving benefits can be seen from the figure in areas where the vehicle stops for a relatively long time, as can be seen between $t = 600$ to 800

s in the figure. A concrete conclusion on the effect of engine restart timing on the effectiveness of the start-stop system cannot be drawn at this time and requires further investigation using other driving routes. Nonetheless, in this limited case, it can be seen that the presence of the air-conditioning system almost nullifies the benefit obtained by the start-stop system. This, however, may depend on the performance of the air-conditioning system itself as better and more efficient systems will mean that users demand less from the air-conditioning unit, and subsequently draw less power from the engine.

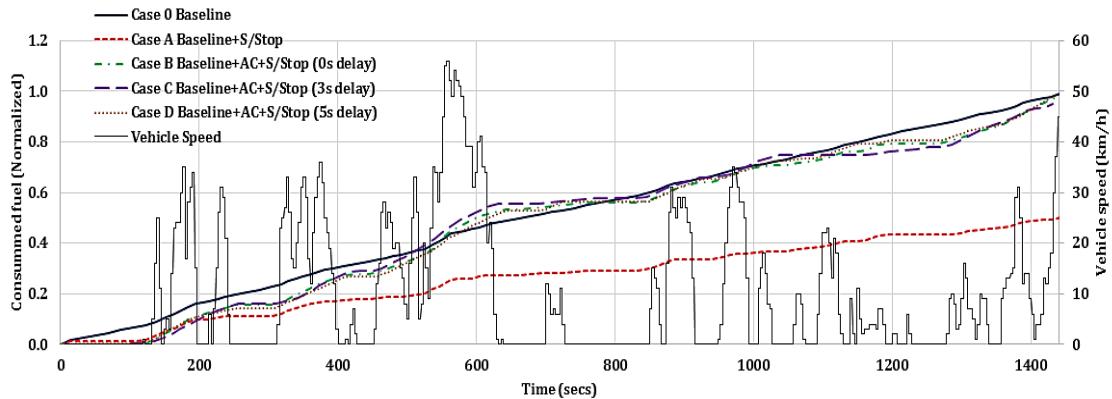

Figure 10. Normalised fuel consumption and vehicle speed against time.

CONCLUSIONS

The fuel consumption benefit of a start-stop technology in a spark ignition engine is analysed with consideration on the cabin comfort temperature. As the start-stop system shuts the engine during vehicle stops, no fuel is expected to be in use. The amount of fuel saved was initially calculated and expected to range between 4.5–49.8 %, with an average of 20.7 %. The amount of fuel saved was then calculated with consideration of the cabin comfort temperature requirement. The percentage of fuel saved dropped significantly to an average of 11.0 %. This brings to the conclusion that the duration of engine shut down during a vehicle stop becomes shorter with the necessity of maintaining the cabin comfort temperature in the Malaysian tropical climate, thus resulted in higher fuel consumption compared to the analysis without the air-conditioning consideration. In further understanding the fuel consumption behaviour with different start-stop restart timing strategies, a one-dimensional engine simulation was carried out on a selected route. The simulation result showed no clear benefit in the start-stop restart timing strategies. The cycle average fuel consumption between each of the strategies varied at less than 4 %. This calls for further investigation into the start-stop system with air-conditioning operations for the optimisation and implementation of the system in maximising the fuel consumption benefit for vehicles in hot climates.

ACKNOWLEDGEMENTS

The authors would like to thank for financial assistance under the sponsors of Universiti Tun Hussein Onn Malaysia (UTHM) (STG Vot U355/FRGS Vot 1589) and Universiti Teknologi Malaysia (UTM) (PAS Vot Q.J130000.2724.02K86). The authors also thank to Imperial College London for providing the laboratory facilities to complete the

simulation work. In addition, the authors would also to thank the Powertrain Department, PROTON Holdings for the collaboration and providing the test vehicle and equipment in the experiments.

REFERENCES

- [1] BioAge Group L. WLTP and RDE tests for measuring emissions come into force in EU tomorrow. Green Car Congress: Energy, technologies, issues and policies for sustainable mobility 31 August, 2017.
- [2] Donateo T, Giovinazzi M. Building a cycle for real driving emissions. Energy Procedia. 2017;126:891-8.
- [3] IQ A. Real driving emissions; 2017.
- [4] Lemazurier L, Shidore N, Kim N, Moawad A, Rousseau A, Bonkoski P, et al. Impact of advanced engine and powertrain technologies on engine operation and fuel consumption for future vehicles. SAE Technical Paper; 2015.
- [5] Wang Y, Chen L, Kubota J. The relationship between urbanization, energy use and carbon emissions: evidence from a panel of Association of Southeast Asian Nations (ASEAN) countries. Journal of Cleaner Production. 2016;112:1368-74.
- [6] Bishop J, Nedungadi A, Ostrowski G, Surampudi B, Armiroli P, Taspinar E. An engine start/stop system for improved fuel economy. SAE Technical Paper; 2007.
- [7] Prucka MJ. Development of an engine stop/start at idle system. SAE Technical Paper; 2005.
- [8] Thitipatanapong S, Noomwongs N, Thitipatanapong R, Chantranuwathana S. A Comparison study on saving fuel by idle-stop system in bangkok traffic condition. SAE Technical Paper; 2013.
- [9] Whittal I. Off-cycle fuel consumption evaluation of Stop-Start systems. SAE Technical Paper; 2012.
- [10] Bagheri F, Fayazbakhsh MA, Cheppudira Thimmaiah P, Bahrami M. Theoretical and experimental investigation into anti-idling A/C system for trucks. Energy Conversion and Management. 2015;98:173-83.
- [11] Abas MA, Salim O, Martinez-Botas R, Rajoo S. Efforts to establish Malaysian urban drive-cycle for fuel economy analysis. SAE Technical Paper; 2014.
- [12] André M, Joumard R, Hickman AJ, Hassel D. Actual car use and operating conditions as emission parameters: derived urban driving cycles. Science of the total environment. 1994;146:225-33.
- [13] Mock P. Real-Driving Emissions test procedure for exhaust gas pollutant emissions of cars and light commercial vehicles in Europe. The International Council On Clean Transportation. 2017.
- [14] Boesch MA. Method and system for inhibiting engine idle stop based on operating conditions. Google Patents; 2015.