

Comparative design and performance of surface water irrigation pumps for smallholder farmers in South and Southeast Asia

W. Sanghirun^{1,3} and W. Asvapoositkul²

¹ The Joint Graduate School of Energy and Environment, King Mongkut's University of Technology Thonburi, 10140 Bangkok, Thailand.

² Department of Mechanical Engineering, Faculty of Engineering, King Mongkut's University of Technology Thonburi, 10140 Bangkok, Thailand.
Phone: +6624709123; Fax: +6624709111

³ Center of Excellence on Energy Technology and Environment (CEE), Ministry of Higher Education, Science, Research and Innovation (MHESI), 10400 Bangkok, Thailand.

ABSTRACT – An experimental study on the performance of various Thai irrigation pump impellers and a newly design conical hollow-shaped impeller was investigated. They were tested experimentally. The design pump based on a similar theory was developed. The objectives of this experiment were to provide data for comparison of Thai irrigation pump impellers, to evaluate, and to improve the current design of Thai irrigation pumps in a cost-effective and energy-efficient manner. The efficiency and design variables of Thai irrigation pump impellers were presented as a function of dimensionless specific speed in the range, $2.1 < N_s < 4.1$. The geometric and design variables as functions of the specific speed and the specific diameter or Cordier diagram presented in this paper could be used as a practical design guide for Thai irrigation pump impellers. This is a preliminary design phase of Thai irrigation pump impellers and the result from this study is intended to make a modest contribution. However, they are facing new challenges that require pump performance improvement and innovative design.

ARTICLE HISTORY

Received: 24th Dec. 2021

Revised: 20th July 2022

Accepted: 26th Aug. 2022

KEYWORDS

Thai irrigation pump impeller

Cordier diagram

Specific speed

Specific diameter

Pump design variables

INTRODUCTION

Smallholder farmers in South and Southeast Asia use surface pumps for year-round, on-farm water control to intensify and diversify their farming system to improve livelihoods. The increase in the number of these pumps has contributed to a significant increase in irrigation over the past 50 years in most of Asia [1]. This type of pump is also widely used in Thailand. Unlike conventional irrigation pumps, the Thai irrigation pump or “Tor Payanak” in Thai consists of a long pipe through which a rotating shaft passes (see Figure 1). The impeller is fixed to the suction end while the other end of the shaft is driven by an engine. The pump was developed in Thailand in 1941 by M.R. Debriddhi Tavakul [2]. Due to its simple design, low price, and efficient low lift pump, small manufacturers and farmers can fabricate by themselves. Since 1957 many manufacturers in Thailand have started fabricating the pump without any technical assistance from the government sector [3]. The pumps have contributed a lot to Thai agriculture as well as the small farm machinery industry [3]. These pumps are used for all sorts of operations where surface water needs to be raised 1-3 m for irrigation and drainage, or for small- and large-scale fish and shrimp farming facilities [4, 5]. In comparison, centrifugal pumps are too heavy and costly for these applications. They are now widely used with modifications to suit local conditions in Southeast and South Asia countries [6, 7]. The bibliography of these irrigation impellers is very limited. In this study, Thai irrigation pumps are reviewed and represented as irrigation pumps for smallholder farmers in South and Southeast Asia. Most Thai irrigation pump impeller manufacturers are family-run businesses. After the first Tor Payanak was introduced, several designs and modifications have been changed according to their expertise and experience usually based on trial and error. Without engineering knowledge, they could find themselves at a considerable disadvantage to develop the impeller strategically, in line with state-of-the-art standards and proven methods. However, the pump has proven to be a versatile pump and has advantages over other pumps with the following news.

On 23 June 2018, the Wild Boars Football Team, aged 11 to 16, was trapped in Tham Luang Nang Non cave in northern Thailand after heavy rainfall [8]. The rescue of the 13 lives was an extraordinary operation due to unprecedented and countless obstacles [9]. To drain the water out of the cave, many different types of pumps were delivered. Upon inspection at the site, it was determined heavy-duty pumps could not be used due to unsuitable terrain [9]. The Thai irrigation pumps were also used in this miraculous operation [10]. The pump was specially designed with a diameter of 490 mm and driven by a diesel engine with a shaft power of 300 hp at a speed of 2,000 rpm, and a flow rate of 100,000 L/min. The 13 pumps were deployed, from which millions of liters of water had been pumped continuously for 75 hours [11, 12]. After that, the rescue continued and succeed.

The main challenge for the future is to design an appropriate impeller that facilitates both trading and the deployment of new technologies. An innovative design of such pumps is a conical hollow-shaped impeller [13-15]. To maintain the Thai irrigation pump advantages, the pump must be lightweight, compact, inexpensive, deliver a large volume of flow at a low pressure efficiently and reliably over a wide range of operating conditions.

In this study, various Thai irrigation pump impellers from different manufacturers and the newly developed conical hollow-shaped impeller are investigated and tested. The performance of such pumps depends on the blade section shape, blade angle, and the number of impeller blades. Experimental determination of these parameters will make it possible to provide for a feasible design of Thai irrigation pumps in a cost-effective and energy-efficient manner. To correctly describe and evaluate pump performance, dimensional analysis is performed. With proper design criteria available, it would be possible to find relations that are independent of the units of measurement, and it must lead to identical results. In the following, the similarity relations will therefore be derived by the methods of dimensional analysis. The main goal of this paper is to examine all available pump geometries, their performance and propose an additional empirical relationship between the specific speed and the specific diameter of pumps that is called the Cordier diagram.

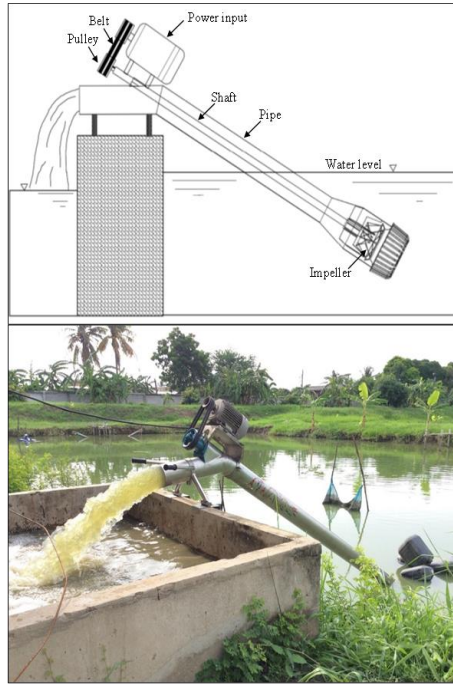

Figure 1. An installation of Thai irrigation pump impellers

PERFORMANCE PARAMETERS

The reviews dealing with dimensionless numbers can be seen in Ruzicka [16]. This method is widely used in various engineering fields. A summary for application to turbomachinery was prepared by many authors (e.g. Japikse & Baines [17] and Dixon & Hall) [18]. The method was successfully demonstrated by Wislicenus [19]. Therefore, this approach is admirably suited to determine the general form and characteristics of the impellers to be designed and developed. The relation between the operating conditions and the geometric form characteristics of the impellers are related by similarity considerations. The dimensionless numbers are as follows.

Flow coefficient:

$$\Pi_Q = \frac{Q}{ND^3} \tag{1}$$

Head coefficient:

$$\Pi_H = \frac{gH}{N^2 D^2} \tag{2}$$

Power coefficient:

$$\Pi_P = \frac{P}{\rho N^3 D^5} \tag{3}$$

where Q is the volume flow rate, N is the rotor shaft speed, D is the rotor blade diameter and P is the shaft power.

Specific speed (N_s) and specific diameter (D_s) are dimensionless parameters rating of pump performance derived from equations involving shaft speed, impeller diameter, flow rate, and differential head at a pump's best efficiency point (BEP). The relationship between the specific speed and the specific diameter of pumps is called the Cordier diagram [20]. It is an essential parameter that distinguishes the different turbomachines. The specific speed and the specific diameter are written as:

$$N_s = \frac{N\sqrt{Q}}{(gH)^{3/4}} = \frac{\Pi_Q^{1/2}}{\Pi_H^{3/4}} \tag{4}$$

$$D_s = \frac{D(gH)^{1/4}}{\sqrt{Q}} = \frac{\Pi_H^{1/4}}{\Pi_Q^{1/2}} \tag{5}$$

$$\eta = \frac{\rho Q(gH)}{P} = \frac{\Pi_Q \Pi_H}{\Pi_P} \tag{6}$$

THAI IRRIGATION PUMP IMPELLER DESIGN

There are various designs of Thai irrigation pump impeller in the market. For the purpose of this work, the design of such impellers is separated into three loose classifications; the propeller, the improved axial or typical impeller, and finally, the conical hollow-shaped impeller by Sanghirun & Asvapoositkul [21]. The basic design parameters of each impeller geometry are given in Figure 2.

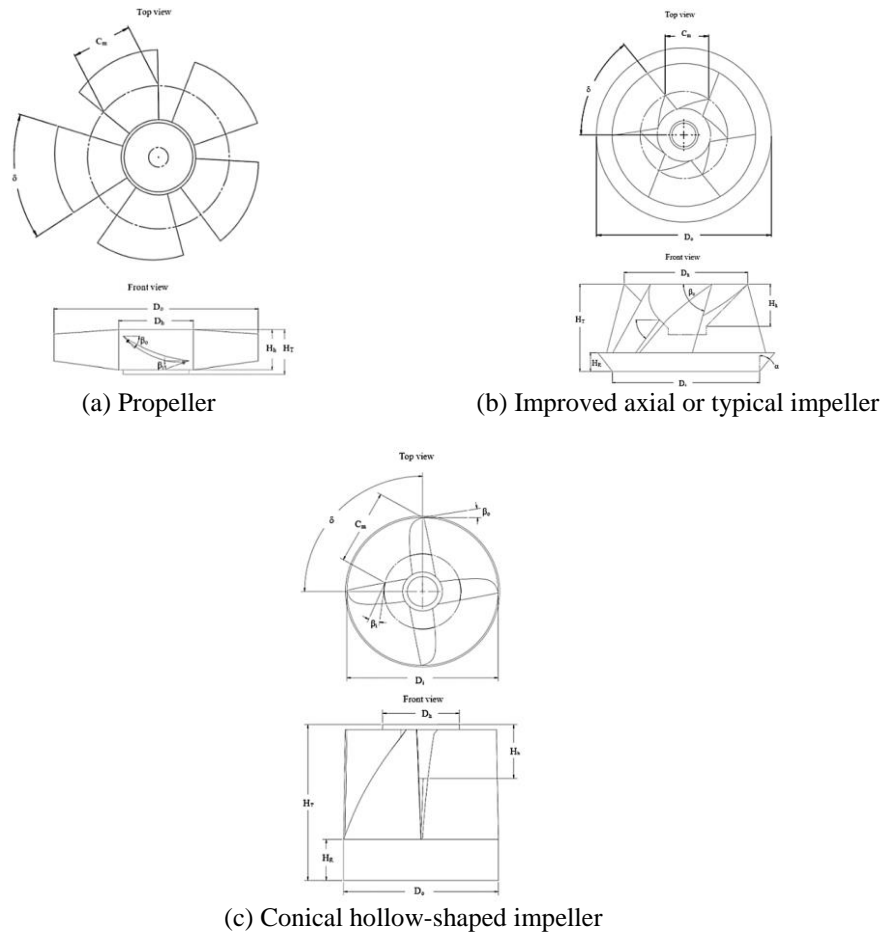
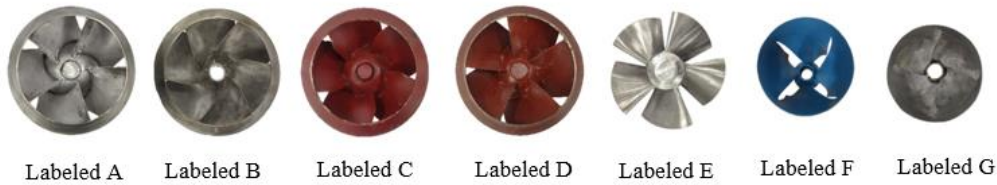

Figure 2. Basic design parameters in Thai irrigation pump impellers

In this study, seven impellers, labeled A – G, are determined. Impeller, labeled E, is a propeller-type with a diameter of 230 mm, 5 blades, inlet, and exit angles at a mean diameter of 1.93° and 55.05°, respectively. Impellers, labeled A – D, are typical impellers with diameters of 240 and 248 mm with 5 to 6 blades. The inlet angles at mean diameter vary from 45° to 61.53°, and the exit angles at mean diameter vary from 45° to 51.54°. Impellers, labeled F - G, are cone-shaped with a diameter of 139 mm, and 4 blades. For impeller, labeled F, inlet and exit angles at mean diameter are 12.28° and 12.78°, respectively. For impeller, labeled G, inlet and exit angles at mean diameter are 29.54° and 16.52°, respectively. The pertinent dimensions of each impeller are given in Table 1. A more detailed of making the conical hollow-shaped impeller refers to Sanghirun and Asvapoositkul [13-15].

Table 1. Design parameters of each impeller

No.	Parameter	Description	A	B	C	D	E	F	G
1	Z	Number of blades	5	6	5	5	5	4	4
2	D_o	Outside diameter of impeller (cm)	24.80	24.00	24.00	24.00	23.00	13.90	13.90
3	D_i	Inside diameter of impeller (cm)	19.00	19.00	17.70	19.00	-	13.60	13.60
4	D_h	Hub diameter of impeller (cm)	14.60	15.10	14.50	14.50	8.40	69.50	69.50
5	H_T	Total height of impeller (cm)	10.20	14.20	11.50	10.70	5.20	14.00	14.00
6	H_h	Hub height (cm)	4.80	7.80	5.10	5.50	5.10	3.70	3.70
7	H_R	Inlet ring height (cm)	2.60	2.70	2.50	2.80	-	4.86	4.86
8	C_m	Chord length (cm)	8.37	8.68	8.83	7.81	6.67	7.59	7.59
9	δ	Volute angle ($^\circ$)	57.93	52.39	56.46	56.91	57.15	90.00	90.00
10	α	Ring angle ($^\circ$)	43.66	45.00	49.91	42.14	-	-	-
11	β_i	Inlet blade angle ($^\circ$)	45.00	52.46	61.53	45.00	1.93	12.28	29.54
12	β_o	Outlet blade angle ($^\circ$)	48.81	49.91	51.54	45.00	55.05	12.78	16.52



EXPERIMENT SETUP AND PROCEDURE

The axial-flow pump facility used in these experiments was designed and built at Mechanical Department, King Mongkut’s University of Technology Thonburi, following JIS B 8302:1990 [22], JIS B 8301:2000 [23] and ISO 9906:2012 [24] standard. It is an open-pit testbed consisting of an 11.8 m³ storage tank, impeller test section and drive motor, and return pipe, shown in the schematic diagram in Figure 3. The test unit is vertically mounted and 200 mm in diameter. When testing pumps with a diameter greater or less than the test unit pipe diameter, an adapter tube is used as shown in Figure 3. The arrangement of the system is illustrated in Figure 4. and Figure 5. The motor is rated at 10 hp (7.5 kW) at 1,430 rpm, 380 volts ac, corresponding to 50.33 N-m torque. Power input to the motor was measured with commercial types of voltmeters and ammeter, having an accuracy of $\pm 0.5\%$. The motor speed could be varied by variable frequency drive. The flow rate was measured with an electromagnetic flowmeter manufactured by Siemens with an accuracy of $\pm 0.2\%$. The total head was measured by a pressure transducer which can be read with an accuracy of $\pm 0.25\%$. The data were stored in a data logger to determine the pump performance. The specifications of the measuring devices are summarized in Table 2.

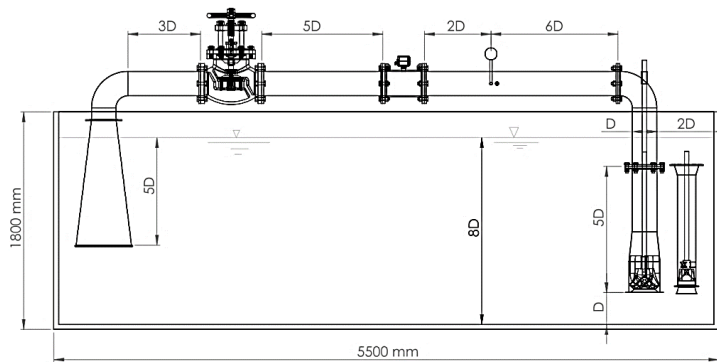

Figure 3. Schematic diagram of the experimental setup (D is a pipe diameter of 200 mm)

The data were measured after reaching the steady-state condition in general 30 minutes after pumping. The impellers, labeled A – E, were tested at a constant speed of 900 rpm and 1,000 rpm due to the recommendation from the manufacturers. The impellers, labeled F – G, were tested at a constant speed of 1,400 rpm due to their design conditions. It should be noted that the diameters were less than the others about 0.6 times with 4 blades. The measurements included the flow rate, pump total head, power input, torque, and rotation speed within the following variations from the test condition. The flow rate, pump total head, power input, and torque was not varied by more than 3%. The rotation speed

fluctuation during the test period did not exceed 1%. During the test, the measured data were recorded at an interval of 1 second for 5 minutes, and then the average was computed for each data.

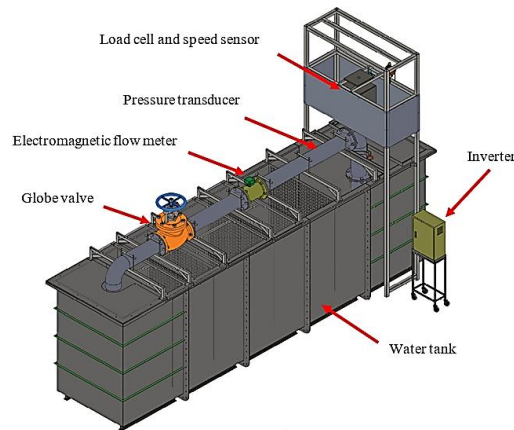

Figure 4. Pump performance test rig



Figure 5. Photograph of pump performance test rig

Table 2. Measuring device specification

Device / Type	Notation	Unit	Range	Accuracy	Resolution
Pressure transducer	P_d (Discharge pressure)	bar	1 - 0bar	$\pm 0.25\%$	0.001
Tension load cell	F (Force of motor)	kg	0 - 50 kg	$\pm 1\%$	0.01
Electromagnetic Flow meter	Q (Volume flow rate)	L/s	0 - 314 L/s	$\pm 0.2\%$	0.1
Power meter	P_m (Motor power input)	kW	0 - 7.5 kW	$\pm 0.5\%$	0.1
Shaft speed sensor	n (Shaft speed)	rpm	0 - 10,000 rpm	$\pm 0.7\%$	1

RESULTS

The performance of pumps is best presented in terms of dimensionless coefficients. These coefficients are the flow coefficient, total head coefficient, power coefficient, and efficiency. The dimensionless characteristics of test data for the pumps (labeled A – G) were plotted as shown in Figure 6. It showed independent of speed and size of each machine where the geometric shape of the pump effect on its operating characteristics could be generally determined. It should be noted that pumps labeled A – D were in a similar design. In this case, an increase in flow coefficient will result in an almost parallel decrease in head coefficient as shown in Figure 6(a). On the other hand, a similar relation was obtained with a slight slope from pumps labeled E - G, respectively. According to Figure 6(a), pumps labeled F - G have higher values of flow coefficients than the others. The plotted in terms of power coefficient was shown in Figure 6(b), and pump

efficiency was shown in Figure 6(c). The relationship among the pumps cannot be generally stated. This means that they depend greatly on the shape of the impeller, and the inlet and exit angle of each design. Since turbomachines of similar design geometry have similar flow mechanisms, they have more or less the same efficiency. The pump labeled E yielded the lowest efficiency at the design point and the pump labeled F yielded the highest efficiency at the design point. It should be noted that the efficiency of modern irrigation pumps can be 65 – 75% [25]. The result from the present study has just 55% from the pump labeled F.

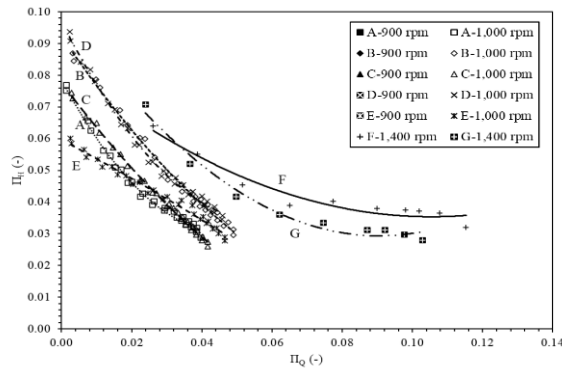

(a) Total head coefficient versus flow coefficient

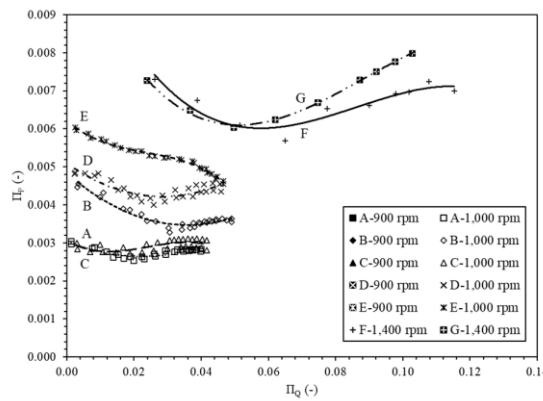

(b) Power coefficient versus flow coefficient

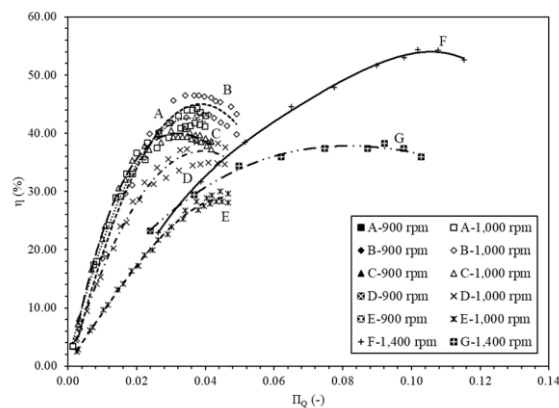

(c) Efficiency versus flow coefficient

Figure 6. Dimensionless characteristics of test data for the pumps (labeled A – G)

The reason for this is that Thai irrigation pump impellers are produced by small shops for domestic distribution without restrictions on a hydraulic design where losses in the pump are not so important. Few of these local companies have done enough testing to develop adequate rating curves. Compare with those manufactured by large corporations for overseas distribution with engineering knowledge and state-of-the-art know-how. Therefore, they are generally cheap to buy with higher operating costs. This can be fairly economical, especially for low-income farmers. Thus, the most important objective of the evaluation is to improve pump performance.

The operation zone at the best efficiency point of each design showed a variation with the flow coefficient. The pump performance and size could well be determined from the dimensionless specific speed and specific diameter. Figure 7 shows the relationship between specific speed and specific diameter for pumps labeled A – G. It should be noted that

these parameters are described the pumps' operating characteristics at the best efficiency of each pump design. The linear relationship is obtained with a low specific speed at a high specific diameter. The empirical equation based on this study of surface water irrigation pumps for smallholder farmers is given in Equation 7. Using this relation, one could obtain the type of the machine (improved axial, propeller, or cone-shaped) and the diameter of the impeller which would meet the operating point (e.g. flow rate and head) at the best efficiency. In this way, the pump design could be determined directly according to certain relative parameters of the pump (e.g. head, flow, and rotating speed of pump). The selection depends on the designer's choice of pump operating data or design constraints, which has obvious limitations.

$$D_s = -0.527N_s + 3.478 \quad (7)$$

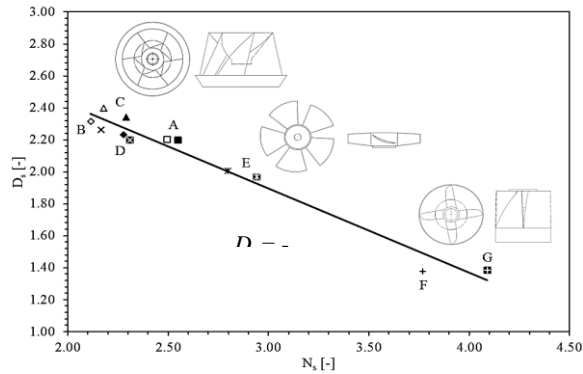

Figure 7. Dimensionless characteristics of test data for the pumps

SUMMARY AND CONCLUSIONS

In this paper, seven Thai irrigation pump impellers with different designs were determined. Tests were conducted and data were analyzed for comparative design and performance. Results showed that pump efficiency depended greatly on the shape of the impeller which was related to head coefficient - flow coefficient characteristics. The geometric and design variables as functions of specific speed and specific diameter or Cordier diagram presented in this paper could be used as a practical design guide for Thai irrigation pump impellers. This relationship was based on measurements with linear relation of high specific speed at low specific diameter. For a given operating point (i.e. flow rate and pressure, and a rotating speed), the diameter of Thai irrigation pumps could be found in the Cordier diagram. The design variables and constraints selected in the present study were described in Tables 1 and Figure 2.

Further development of the pump depends on knowledge of pump design and its relationship to the internal flow. To improve the current design of Thai irrigation pumps in a cost-effective and energy-efficient manner, CFD will be applied to investigate. With a complete description of the pump geometry, the experimental results provide an excellent test case for comparison with numerical computations or CFD simulations. The present data should be regarded as tentative. Currently, work is in progress for design improvements by applying the entropy generation principle to identify the regions associated with losses.

ACKNOWLEDGMENTS

The authors would like to express their gratitude to the Faculty of Engineering, The Petchra Pra Jom Klao Ph.D. Scholarship, Grant No. 48/2559, King Mongkut's University of Technology Thonburi and the Center of Excellence on Energy Technology and Environment (CEE), Ministry of Higher Education, Science, Research and Innovation (MHESI) for the financial support provided to perform this study.

CONFLICTS INTEREST

The authors declare that there is no conflict of interest regarding the publication of this paper.

REFERENCES

- [1] T. Shah, R. Namara, and A. Rajan, Accelerating irrigation expansion in Sub-Saharan Africa : Policy Lessons from the Global Revolution in Farmer-Led Smallholder Irrigation. International Water Management Institute (IWMI), 2020.
- [2] D. Tavakul, "Debriddhi pump," (in Thai), Kasikorn Journal, vol. 14(2), pp. 281-283, 1941.
- [3] W. Chinsuwan and B. Cochran, "The axial-flow low-lift pump in Thailand," in Proceedings of International Conference on Small Farm Equipment for Developing Countries: Past Experiences and Future Priorities, 1986, pp. 195-203.

- [4] T. J. Krupnik, S. Santos Valle, A. J. McDonald, S. E. Justice, I. Hossain, and M. K. Gathala, *Made in Bangladesh: Scale-appropriate machinery for agricultural resource conservation*. International Maize and Wheat Improvement Center (CIMMYT), Mexico, 2013, pp. 66-78.
- [5] F. Molle, T. Shah, and R. Barker, "The groundswell of pumps: Multilevel impacts of a silent revolution," in *ICID-asia meeting*, Taiwan, Nov. 10 - 12 2003, pp. 1-18.
- [6] E. Lichtfouse, M. Navarrete, P. Debaeke, S. Véronique, and C. Alberola, *Sustainable agriculture reviews* Vol. 18. Springer, Netherlands, 2017.
- [7] S. Yu and J. S. Colton, "Mixed-flow irrigation pump design optimization for Bangladesh," in *The 21st International Conference on Engineering Design (ICED 17) Vancouver, Canada, Aug. 21-25 2017*, vol. 1, pp. 071-080.
- [8] BBC. News. "The full story of Thailand's extraordinary cave rescue." <https://www.bbc.com/news/world-asia-44791998> (accessed Dec. 8, 2021).
- [9] Wikipedia. "Tham Luang Cave Rescue." https://en.wikipedia.org/wiki/Tham_Luang_cave_rescue (accessed Dec. 8, 2021).
- [10] Ministry of Culture in Thailand, "The Tham Luang Cave Rescue: A Global Mission," Thailand, Jun. 23 - Jul. 10 2018.
- [11] MGR. News. "Thai Irrigation Pump Helping the Wild Boars Team Return to Home." https://www.matichon.co.th/region/news_1039913 (accessed Dec. 8, 2021).
- [12] Reuters. News. "Thailand Cave Rescue Lucky 13." <https://www.reuters.com/article/us-thailand-accident-cave-idUSKBN1JT059> (accessed Dec. 8, 2021).
- [13] W. Sanghirun and W. Asvapoositkul, "Impeller " (in Thai), Thailand Patent No. 72934, 2019.
- [14] W. Sanghirun and W. Asvapoositkul, "Impeller for pump " (in Thai), Thailand Patent No. 76916, 2020.
- [15] W. Sanghirun and W. Asvapoositkul, "Impeller for pump " (in Thai), Thailand Patent No. 80214, 2020.
- [16] M. Ruzicka, "On dimensionless numbers," *Chemical Engineering Research and Design*, vol. 86, no. 8, pp. 835-868, 2008, doi: <https://doi.org/10.1016/j.cherd.2008.03.007>.
- [17] D. Japikse and N. C. Baines, *Introduction to turbomachinery*. Oxford University Press, Oxford, United Kingdom, 1994.
- [18] S. L. Dixon and C. Hall, *Fluid mechanics and thermodynamics of turbomachinery*, 7th ed. Butterworth-Heinemann, 2014.
- [19] G. F. Wislicenus, *Preliminary design of turbopumps and related machinery*. National Aeronautics and Space Administration (NASA), California, United States, 1986.
- [20] P. Epple, F. Durst, and A. Delgado, "A theoretical derivation of the Cordier diagram for turbomachines," *Proceedings of the Institution of Mechanical Engineers, Part C: Journal of Mechanical Engineering Science*, vol. 225, no. 2, pp. 354-368, 2011, doi: <https://doi.org/10.1243/09544062JMES2285>.
- [21] W. Sanghirun and W. Asvapoositkul, "On the flow visualization for assessment in the analysis and design of a conical hollow shaped impeller," in *The 14th Asian Symposium on Visualization*, Beijing, China, May 22-26 2017.
- [22] *Measurement Methods of Pump Discharge*, JIS B : 8302, 1990.
- [23] *Rotodynamic Pumps-Hydraulic Performance Acceptance Tests - Grades 1 and 2*, JIS B : 8301, 2000.
- [24] *Rotodynamic pumps-Hydraulic performance acceptance tests-Grades 1, 2 and 3*, ISO 9006, 2012.
- [25] Natural Resources Conservation Service, "Chapter 8 Irrigation Pumping Plants," in *Part 623 Irrigation National Engineering Handbook*. Department of Agriculture, United States, 2016.