

RESEARCH ARTICLE

Development of Vehicle Alcohol and Driver Seat Detection Integrated with Engine Starting System

A. H. Mohamed^{1,2}, M. H. Harun^{1*}, F. Ahmad¹, B. Z. Xian¹ and U. Ubaidillah³

¹Faculty of Mechanical Technology and Engineering, Universiti Teknikal Malaysia Melaka, 76100 Durian Tunggal, Melaka, Malaysia

²Kolej Kemahiran Tinggi MARA Masjid Tanah, KM1, Persiaran Paya Lebar, Ramuan China Besar, 78300 Masjid Tanah, Melaka, Malaysia

³Faculty of Engineering, Universitas Sebelas Maret, Kota Surakarta, 57126 Jawa Tengah, Indonesia

ABSTRACT – In recent years, alcohol-impaired driving has contributed significantly to fatal road accidents. A World Health Organization (WHO) report in 2018 revealed that there were 2,364 drunk driving-related accidents between 2010 and 2018, resulting in 1,196 deaths. On average, 132 fatalities occur annually, with one life lost every three days due to alcohol-related crashes. This alarming trend highlights the urgent need for effective prevention strategies. To address this issue, researchers have conducted numerous studies on alcohol detection systems for drivers. While many devices can detect the presence of alcohol, detection alone is insufficient to prevent drunk driving. Effective systems must be integrated with the vehicle's starting mechanism and designed to prevent circumvention of driver monitoring. Such integration ensures that if a driver's blood alcohol concentration (BAC) exceeds the legal threshold, the vehicle remains immobilized, thereby preventing impaired individuals from operating it. Therefore, this study presents the development of the Vehicle Alcohol and Driver Seat Detection Integrated with Engine Starting System (VADSS). This system employed Arduino UNO, a seat occupancy sensor, a door switch and an MQ-3 alcohol sensor, which responded sharply when BAC levels exceeded 0.05%. Experimental results showed that the MQ-3 alcohol sensor resistance increased from 180 Ω to 920 Ω within one second, activating the vehicle starting mechanism. Furthermore, the system verified that the driver was properly seated, ensuring the engine would only start when the individual was sober and present. By integrating alcohol detection with the vehicle's starting mechanism and seat verification, VADSS minimizes opportunities for manipulation and provides an effective approach to reduce drunk driving incidents.

ARTICLE HISTORY

Received : 27th Nov. 2024

Revised : 08th July 2025

Accepted : 07th Aug. 2025

Published : 15th Nov. 2025

KEYWORDS

Drunk driving

MQ-3 sensor

Arduino UNO

Drunk driving detector

Vehicle starting system

1. INTRODUCTION

Drunk driving is one of the many causes of land vehicle accidents. According to the National Highway Traffic Safety Administration (NHTSA) in the United States, on average from 2014 to 2023, there were 11,000 people every year who died in accidents related to drunk driving [1-2]. Drunk driving, as defined by Merriam-Webster, is the act of operating a vehicle while one's physical and mental abilities are impaired by alcohol, usually indicated by a blood alcohol concentration (BAC) that exceeds the legal limit. A period of drinking will lead to intoxication and cause a person to become emotionally unstable, feel tired, and become drowsy. Drunk people will have blurry vision, lose body balance and coordination. The worst situation is losing the ability to make judgments, memory and perception. Alcohol overdose occurs when there is too much alcohol in the bloodstream for certain parts of the brain to perform basic life functions [3]. Overdosing may result in severe brain damage or death [3]. In Singapore, a person may be charged criminally if their breath alcohol content is greater than 35 micrograms per 100 ml of breath, as reported by Low [4].

Drunk driving is defined as driving a vehicle with a BAC of 0.08% or above [5]. Operating a vehicle while inebriated or under the influence of drugs or alcohol is another definition of drunk driving. Driving under the influence (DUI), operating while intoxicated (OWI), driving while intoxicated (DWI), or the popularly used term "drunk driver" are all terminologies used to describe impaired driving [6-7]. However, some drunk drivers may not even display any signs of intoxication, but this does not make the situation any less dangerous [8-9]. It is also crucial to remember that driving under the influence of any amount of alcohol is illegal and can lead to significant repercussions [10]. Even at low alcohol level in the bloodstream can affect a driver's judgment. To drive safely, a person must remain focused, make sound decisions, and react quickly to changes in road conditions [6-7]. Therefore, any level of alcohol consumption should be considered drunk driving.

Vehicle accidents occur daily worldwide due to various factors, with drunk driving being one of the most significant contributors. According to [11-13], in the United States in 2014, 9,967 individuals died as a result of drunk driving, resulting in an estimated economic cost of \$44 billion. Furthermore, the prevalence of such incidents has gradually increased over the years. From 2020 onwards, numerous drunk driving accidents were reported almost daily in the media.

This increase may be due to the COVID-19 pandemic, which limited recreational activities, or to heightened life stress leading to increased alcohol consumption. Although the World Health Organization (WHO) and the Malaysian Transport Ministry have reported that Malaysia has one of the lowest rates of road fatalities caused by drunk driving globally, the number of deaths from drunk driving accidents in the country has steadily risen since 2014 [14]. This trend highlights the growing seriousness of this problem in Malaysia. According to [15-16], Malaysia also has one of the most lenient legal limits for BAC worldwide. Malaysians are permitted 0.08% BAC, while Nepal and Australia enforce 0% limit, China and Russia permit 0.02%, and Hong Kong and Thailand enforce 0.05%. Higher BAC levels significantly impair drivers' attention and responsiveness, especially after consuming alcohol [17-18]. These factors contribute to the ongoing increase in drunk driving accidents in Malaysia in recent years.

In recent years, there has been growing interest in using technology to detect alcohol impairment in drivers. This includes the application of sensors and cameras to identify physical signs of impairment, as well as the use of machine learning algorithms to analyze driving patterns and detect deviations from normal behavior. Numerous researchers have explored similar systems over the past decade. For example, Dharani et al. [19] proposed a drunk and drive detection system to promote safer driving. Similarly, Okengwu and Taiwo [20] designed an in-vehicle alcohol detection and speed control system. They detailed the hardware and software components of their system and evaluated its performance through both simulations and real-world testing. Another system detected drunk driving based on multivariate time series classification [21-22], which was designed to prevent a vehicle from starting if alcohol levels exceeded the legal threshold. This study also involved simulation and real testing to assess system effectiveness. Most of the existing technologies are passive alcohol detection systems, which typically provide only a warning when alcohol is detected in the driver's breath. However, these existing technologies lack reliability and may lose effectiveness under certain conditions due to sensor limitations or interference from external factors. Furthermore, the completeness of these technologies is insufficient, as some contain vulnerabilities that allow drivers to bypass the system. Therefore, this study aims to develop a system that integrates drunken driver detection with the vehicle's engine starting mechanism and driver presence verification.

This paper is organized as follows: Section 1 introduces the study and reviews relevant preliminary work. Section 2 discusses the component design of the Vehicle Alcohol and Driver Seat Detection Integrated with Engine Starting System (VADSS). Section 3 presents the equation used to determine the alcohol content detected by the alcohol sensor. Section four describes the conceptual prototype development of VADSS. The results of this study are discussed in Section 5, and finally, Section 6 presents the conclusion.

2. COMPONENT DESIGN

The first step is to determine the components required, as well as the overall system flow, for the Vehicle Alcohol and Driver Seat Detection Integrated with Engine Starting System (VADSS). Figure 1 depicts the operation of the proposed system, while Figure 2 depicts the system block diagram.

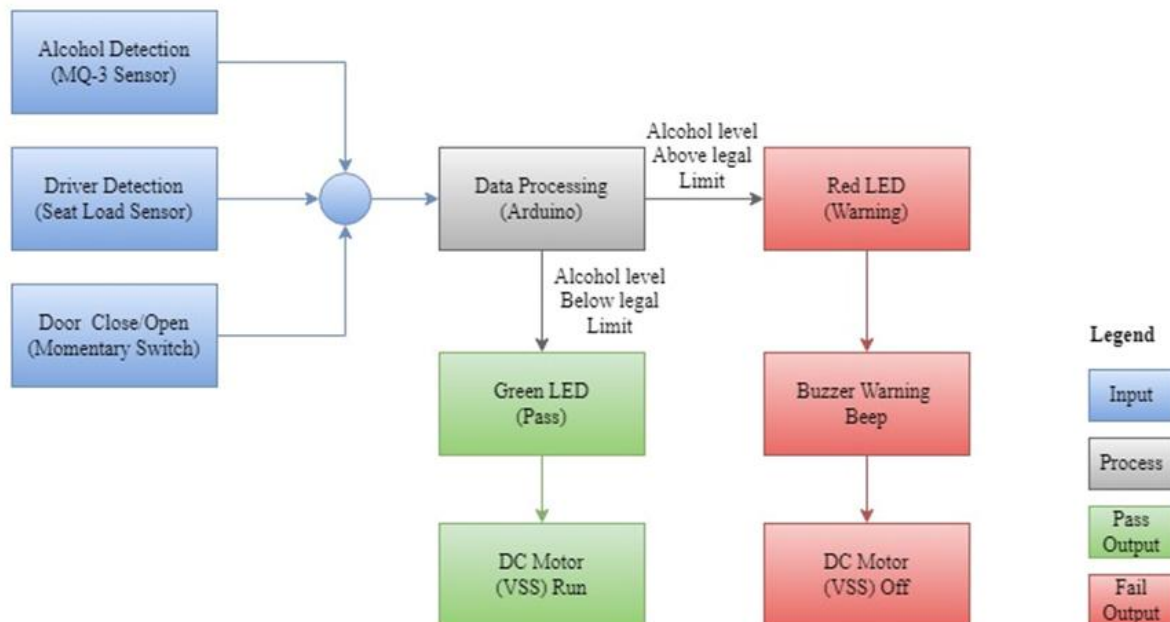

Figure 1. Workflow of VADSS system

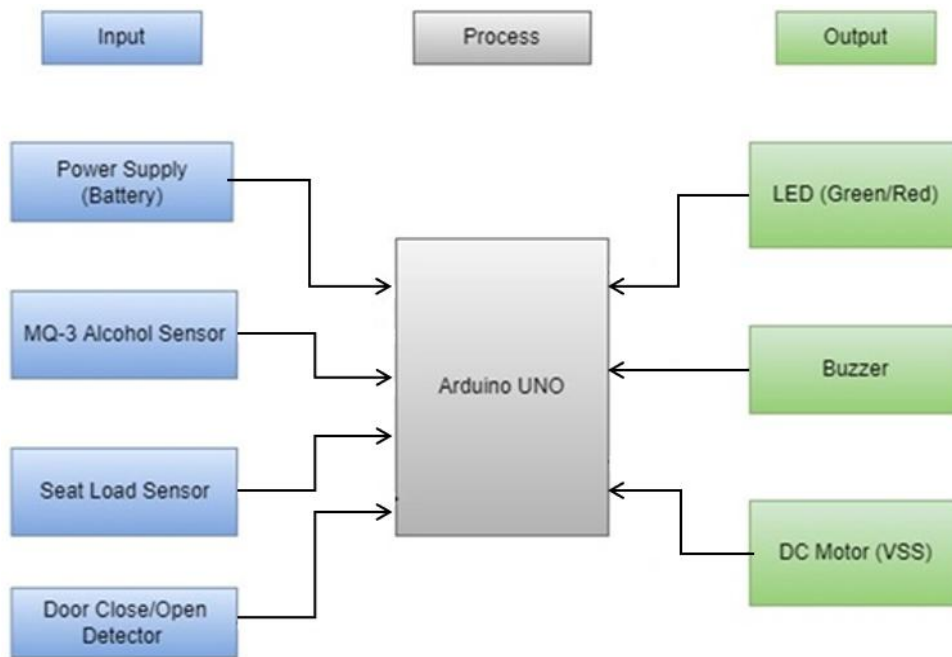

Figure 2. VADSS system block diagram

2.1 Arduino UNO

The ATmega328P microprocessor was used in the Arduino UNO microcontroller board. The board featured 14 digital input/output pins (six of which provided PWM outputs), six analog inputs, a 16 MHz ceramic resonator, a USB connection, a power connector, an ICSP header, and a reset button. Figure 3 shows the Arduino UNO, an open-source microcontroller capable of interfacing with various interconnects and utilized in embedded systems and inter-electronic applications. It can be connected to the computer via USB connection and powered either through alternating current (AC)-to-direct current (DC) converter or DC battery. The Arduino UNO serves as the system's brain, where information is processed, and decisions are made based on the computer code stored in memory.



Figure 3. Arduino UNO board

The VADSS system was connected to the power supply using an Arduino UNO board. This control unit received and processed the signals produced by the semiconductor sensor. It was controlled by computer code loaded on the board that, when specific criteria were fulfilled, illuminated an LED, activated a buzzer, and controlled the starter motor. The Arduino UNO uses a Peripheral Interface Controller (PIC), which can withstand voltages of up to 12V, making it compatible with all cars. The specifications of the Arduino UNO are listed in Table 1. Since the program size was not large, the Arduino UNO is ideal for a system that includes two sensors, three LEDs, two buzzers, a DC motor, and some additional inputs. As a result, there was no limitation in using this board, and the system was able to handle data with high precision, resulting in a very fast response and an effective alcohol detection device. Since it is compatible with great personalization potential, the Arduino UNO was employed to suit the design requirements of this study.

Table 1. Specification of Arduino UNO

Specification	Details
Microcontroller	ATmega328P
USB Type	USB-B
Built-in LED Pin	13
Digital I/O Pins	14
Analog Input Pins	6
PWM Pins	6
I/O Voltage	5V
Input Voltage	7-12V
DC Current per I/O Pin	20mA
Flash Memory	32KB
SRAM	2KB
Clock Speed	16MHz

2.2 MQ-3 Alcohol Sensor

The MQ3 sensor is one of the most widely used and cost-effective. It has been applied in many alcohol measurement instruments. The sensing unit of this sensor uses a metal oxide semiconductor (MOS), which detects changes in the resistance of the sensing element when exposed to alcohol. By incorporating the sensor into the voltage divider network, the alcohol concentration can be determined. Figure 4 shows the MQ3 alcohol sensor, which operates at 5 V DC and consumes approximately 800 mW. This device can detect alcohol concentrations ranging from as low as 25 parts per million (ppm) to as high as 500 ppm. The MQ-3 sensor also has adjustable sensitivity. By turning the controller on the sensor clockwise, sensitivity can be increased, while turning it counterclockwise decreases sensitivity. This function allows the user to adjust sensitivity according to the purpose, environment, and situation.

The word concentration is used to express the quantity of gas present in the air divided by the volume of air when measuring gases. The two most commonly utilized units of measurement are parts per million and percent concentration. Parts per million expresses the ratio of one gas to another. For example, an alcohol concentration of 500 ppm means that out of one million gas molecules, 500 are alcohol, while the remaining 999,500 are other gases.



Figure 4. MQ-3 sensor

2.3 Light Emitting Diode

The light-emitting diode (LED) bulb is a device that, when activated, emits a strong beam of light. In this study, red, blue and green LEDs were used. The red LED illuminated when the detected alcohol exceeded the legal limits, alerting the passengers in the car cabin that the driver's blood alcohol concentration had surpassed the legal limits. The green LED signified that the driver had passed the alcohol test, while the blue LED indicated that the driver was not seated or the door was not closed. Figure 5 depicts the LEDs used in the system.

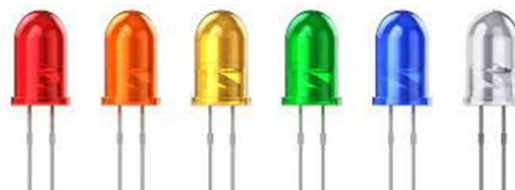

Figure 5. LED bulb

2.4 Buzzer

One of the important warning components in the system was the piezoelectric buzzer, as shown in Figure 6. When a voltage or signal was received, this device produced a beeping noise or buzzing sound, depending on the setting. There

are three common types of buzzers: active buzzers, passive buzzers, and piezoelectric buzzers. The piezo-electronic buzzer is composed of a piezo-electrical substance with two electrodes and is considered the simplest and most basic type. Its primary purpose is to attract the attention of nearby individuals. In this alcohol detection system, the buzzer was triggered when the driver was inebriated, when the door was not closed, or when the seat was unoccupied. For effective operation, the buzzer required an oscillator, such as a microcontroller. The buzzer is cost-effective, produces a loud, high-quality sound, and consumes relatively little power. The parameters of the piezo-electronic buzzer used in this study are detailed in Table 2.



Figure 6. Piezoelectric buzzer

Table 2. Details of the piezo buzzer

Details	Large Piezo Buzzer
Minimum Sound Output at 10 cm	95 dB
Rated Voltage	12 VDC
Operating Voltage	3~24 VDC
Resonant Frequency	3900±500 Hz
Max. Current Consumption	10 mA
Tone Nature	Continuous
Alarm Diameter	22 mm
Alarm Height	10 mm

This piezo-electronic buzzer was used to generate the essential warning sound for the system. When the alcohol level measured by the MQ-3 sensor exceeded the predetermined threshold, the buzzer was activated. It also sounded when the system detected that the driver was not seated or that the door was not closed. The buzzer was inexpensive, simple to integrate with the Arduino board, and readily available from local electronics stores or online shopping platforms.

2.5 Direct Current Motor

A direct current (DC) motor is a rotating electrical motor that transforms DC electrical energy into mechanical energy. It is one of several types of rotary electric motors. The operation of a DC motor is based on magnetic field forces, which can be classified into two main categories. Most DC motors incorporate an internal mechanism that periodically switches the direction of current in a motor component, achieved either electromechanically or electronically. The speed of a DC motor can be controlled over a wide range by changing the supply voltage or raising the current intensity in the primary winding. The universal motor, as shown in Figure 7, is a compact, light, brushed motor that runs on DC and is utilised in conjunction with other components. Table 3 provides more information on DC motors.



Figure 7. DC motor

Table 3. DC motor specifications

Item	Specification
Rated Voltage	6 V
No. load speed	9100 ± 1800 rotations per minute
No. load current	70 mA
Operating voltage	1.5 V to 12 V
Starting Torque	20 gcm (depends on blade used)
Starting current	500mA
Insulation Resistance	> 10 Ω
Rotation Direction	Clockwise at positive terminal
Axis Diameter	2 mm

2.6 Seat Occupancy Sensor

A seat occupancy sensor is an important feature of the airbag safety system, as it informs the airbag control unit (ACU) or electronic control unit (ECU) whether the seat is occupied or vacant. Various types of seat occupancy detection sensors are available on the market nowadays; However, in this study, an inductive type of seat occupancy sensor was used. When a person sits on the seat, the sensor’s built-in springs compress, reducing the distance between an inductor and a ferrite plate. This change alters the sensor's inductance, which is then converted into a signal indicating that the driver is seated. In simple terms, the inductive sensor produces a signal or voltage when the seat is occupied and transmits it to the control unit. A common example of an inductive seat occupancy detection sensor is shown in Figure 8, while its specifications are presented in Table 4.



Figure 8. Inductive seat occupancy detection sensor

Table 4. The tractor parameters

Item	Specification
Size	6.97in x 6.3in
Single point working weight	150g to 180g
Trigger weight	30kg and above
Working voltage	3V DC
Working current	<100mA
Response time	10 ms
Working temperature	-30 to 80°C
Insulation impedance	20MΩ
Static resistance	>10MΩ
Trigger resistance	0-150Ω
Durability	>1000k times

2.7 Door Close/Open Detector

A door condition detector, also referred to as a door switch, is an electrical contact device mounted on a doorframe that operates by opening and closing a circuit as the door is opened or closed. In this study, the door switch was replaced with a momentary switch, which exhibited the same characteristic as the door switch. The momentary switch closed the circuit when the door was closed and opened the circuit when the door was opened. Figure 9 shows the momentary switch used in the system.



Figure 9. DS316 push button switch momentary

3. ALCOHOL CONTENT EQUATION

Any alcohol present in a driver's breath is oxidized at the anode, generating acetic acid:

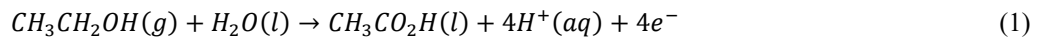

At the cathode, atmospheric oxygen is reduced:



The overall reaction involves the oxidation of ethanol to acetic acid and water.

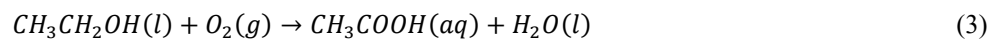

This chemical reaction was sensed by the MQ-3 alcohol sensor, which converted it into sensing resistance (signal) that was transmitted to the microcontroller for future processing. Within the microcontroller, the signal from the sensor was processed to calculate the total BAC. According to the datasheet, the MQ-3 sensor could detect a maximum concentration of 0.4 mg/L, which corresponded to a sensing resistance of 20,000 Ω . In Malaysia, the legal limit for driving is 0.05 mg/L alcohol concentration. Based on the Rs/Ro graph provided in the datasheet, 0.05% BAC corresponded to 800 Ω . This resistance value of 800 Ω was established as the threshold in the programming code to distinguish between legal and illegal driver alcohol concentrations in the detection system.

4. CONCEPTUAL PROTOTYPE DEVELOPMENT

The simulation, data and testing for the VADSS conceptual prototype are discussed in detail. In the initial stage of conceptual prototype development, TinkerCAD software was used to generate the design concepts based on various projects identified in the literature review. The software was used to build the circuit, and the program code was created to test the circuit. As demonstrated in Figure 10, the TinkerCAD platform was used to depict the VADSS concept design.

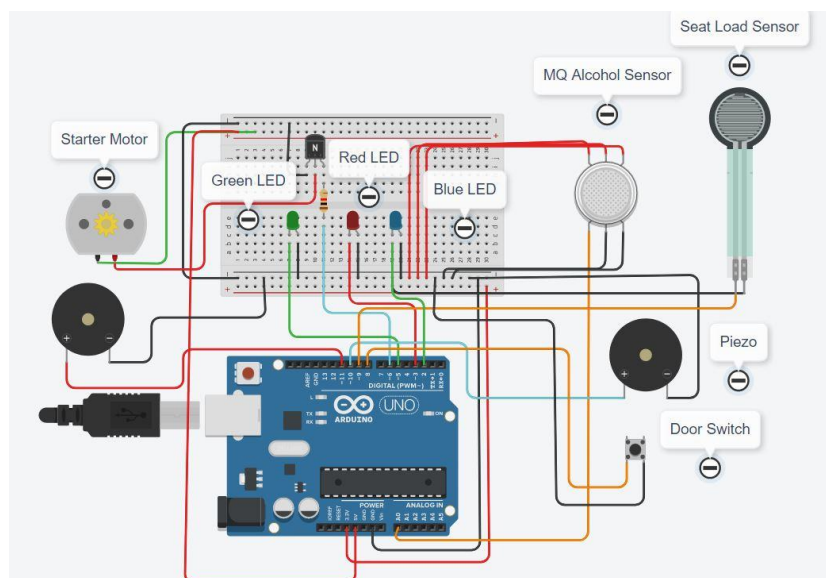

Figure 10. VADSS concept design

4.1 Simulink Block Diagram

Every new microcontroller-based device, such as an Arduino, must be programmed in C++ or another suitable programming language. In this study, the microcontroller was programmed using MATLAB/Simulink software [23-24]. Programming is essential to operate the sensor and other components in accordance with the system's parameters. The Simulink model must be uploaded to ensure that each component functions properly, making programming the "brain" of the system. The new system was developed based on a pre-programmed block diagram model, and the program was designed to provide a very fast response and high accuracy upon start-up.

The MATLAB/Simulink software, along with the Arduino simulation add-on packages, was installed to build the programming code for the system and deliver it to the microcontroller. In this system, the block diagram model was designed to measure parameters such as alcohol concentration, load on the seat, and door condition, and to determine the activation of the light, sound warning signal, DC motor operation, and other components based on the driver's alcohol level in the cabin. During data processing, the system decided whether to activate the LED light indicator, buzzer sound, and motor operation. The concept block diagram model of the system is depicted in Figure 11, and the overall system flow is illustrated in Figure 12.

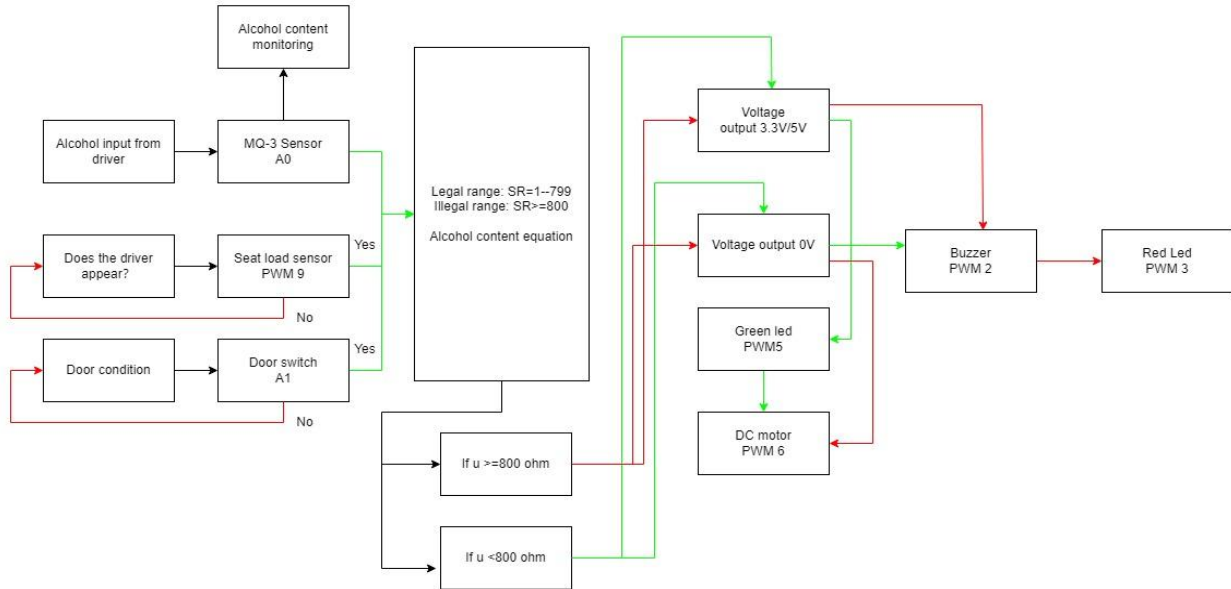

Figure 11. Concept block diagram model of VADSS

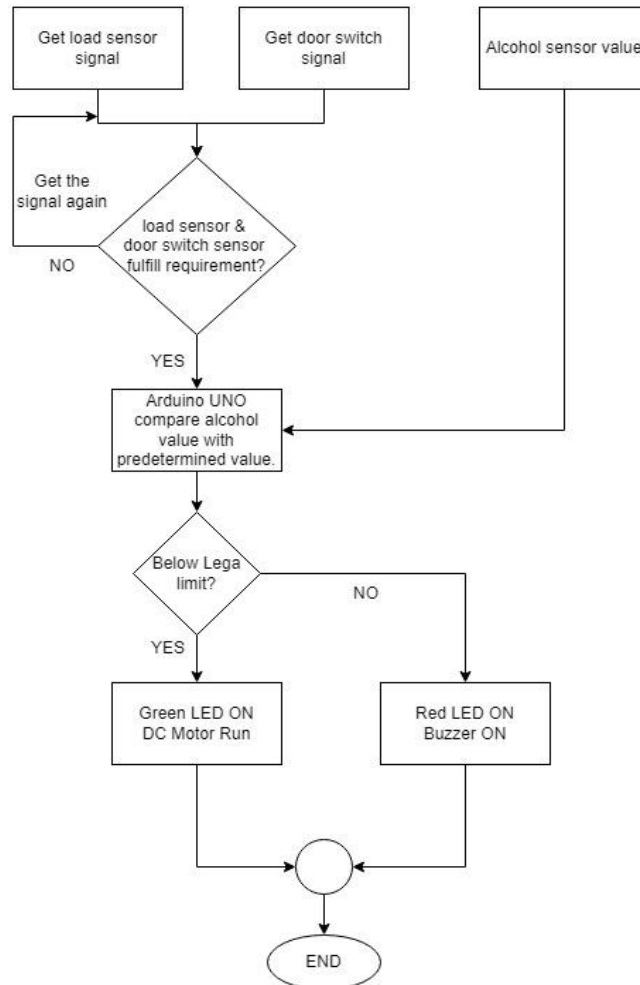

Figure 12. System flow chart

4.2 Conceptual Prototype Construction

To construct the prototype, all of the hardware and software components listed in Table 5 were integrated. The Arduino UNO has been connected to the MQ-3 alcohol sensor, buzzer, LED, seat sensor, momentary switch, and DC motor. The VCC pin on the MQ-3 alcohol sensor was connected to the 5V pin of the Arduino board, while its ground was connected to the ground pin, and the output pin was linked to the analogue input pin (A0). The signal terminal (Red) of the seat sensor was connected to one of the PWM digital slots of the Arduino Uno, while the negative terminal (black) was connected to ground. Two buzzers were connected, with their ground and positive terminals attached to PWM pins 10 and 11, respectively. The LED was divided into three categories: red, blue and green. PWM pin 3 was linked to the red LED, while PWM pin 5 was connected to the green LED, and pin 2 was connected to the blue LED, with both LEDs grounded accordingly

The DC motor was the most challenging component to integrate, as it could not be connected directly to the board due to insufficient operating voltage. To address this, a transistor and a resistor were used to amplify the voltage to a suitable level for the DC motor. The motor's positive terminal was connected to the 5V pin, while the negative terminal was connected to the transistor's collector pin. A resistor linked the transistor's base pin to PWM Pin 6, and the emitter pin was connected to the board ground pin, completing the DC motor grounding. The signal pin of the momentary switch (door switch) was connected to the D8 of the Arduino Uno, while another pin was connected to ground. After assembling all components, the prototype was connected to a computer to upload the programming code from MATLAB/Simulink. Figure 13 depicts the final conceptual prototype.

Table 5. List of software and hardware components

No.	Type of Component	Component Name
1	Software	MATLAB/Simulink
2	Hardware	MQ-3 alcohol sensor
3	Hardware	Buzzer
4	Hardware	LED
5	Hardware	DC motor
6	Hardware	Seat sensor
7	Hardware	Momentary switch

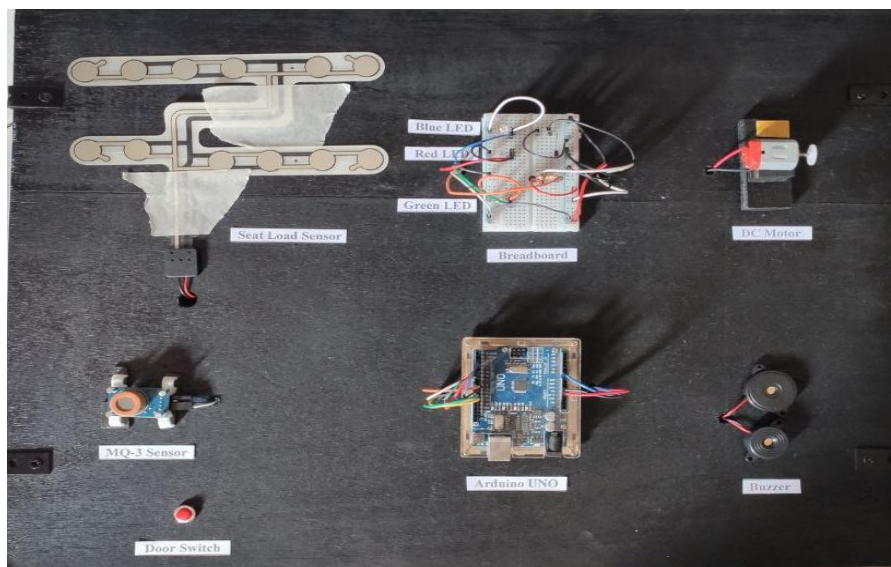

Figure 13. VADSS conceptual prototype

5. RESULT AND DISCUSSION

In the simulation phase, daily driving scenarios were used to test the prototype and evaluate the effectiveness of the VADSS. Additionally, the system was tested under common disturbances to assess its reliability. All simulation results are discussed. Testing the conceptual prototype not only allows the developers to evaluate its functionality, accuracy and reliability, but also helps identify weakness points of the prototype that may be overlooked during development [25-26]. To determine the accuracy of the alcohol sensor used in the VADSS, the alcohol sensing values were compared with those obtained from a digital portable breathalyzer.

5.1 Graph Alcohol Sensing Value without Alcohol

According to research by Al-Youif et al. [27], when no alcohol is detected by the MQ-3, the sensing value typically ranges between 80 Ω and 120 Ω and remains relatively constant. During the no-alcohol simulation, the sensing value from the MQ-3 alcohol sensor ranged from 170 Ω to 190 Ω , which is comparable to the values reported in the literature. However, this value may vary depending on the composition of the surrounding air during testing. Figure 14 shows the alcohol sensing values recorded from MATLAB/Simulink during the simulation. When no alcohol was present in the air passing through the sensor, the readings remained low and constant.

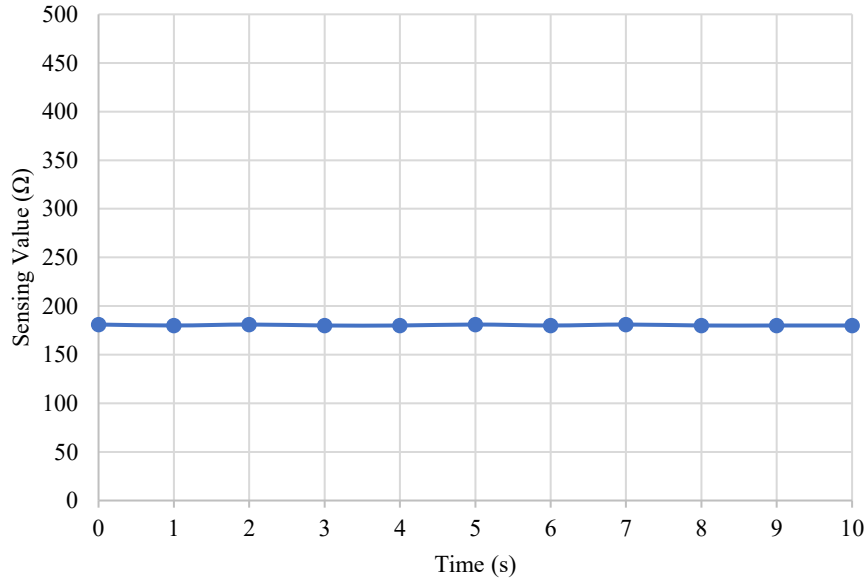

Figure 14. Alcohol sensing value when no alcohol detected

5.2 Graph Alcohol Sensing Value with Alcohol Below Legal Limit

In the below-legal-limit alcohol simulation, the sensing values from the MQ-3 alcohol sensor increased from approximately 180 Ω to a peak of around 600 Ω [28-29]. During the simulation, when the sensor detected alcohol, the sensing value rose rapidly, indicating that the MQ-3 sensor was highly sensitive to alcohol and capable of providing a fast response to the system. According to Francis et al. [30], the sensing voltage of MQ-3 increased instantly from 4.2 V to 4.93 V upon alcohol detection, further demonstrating its rapid response. Figure 15 shows the alcohol sensing value recorded from MATLAB/Simulink during this simulation. The graph indicated that the MQ-3 sensor responded within approximately 0.1 s. It is evident from Figure 15 that genuine breath alcohol produced a sharp rise followed by a gradual decay in the sensor response [31]. This distinct temporal profile suggests that the MQ-3 sensor is highly sensitive to ethanol and can effectively differentiate it from common volatile substances, such as hand sanitizer or perfume, which typically cause short-lived and irregular spikes. This behavior supports the use of time-domain filtering and decay pattern analysis to reduce false positives in automotive alcohol detection systems.

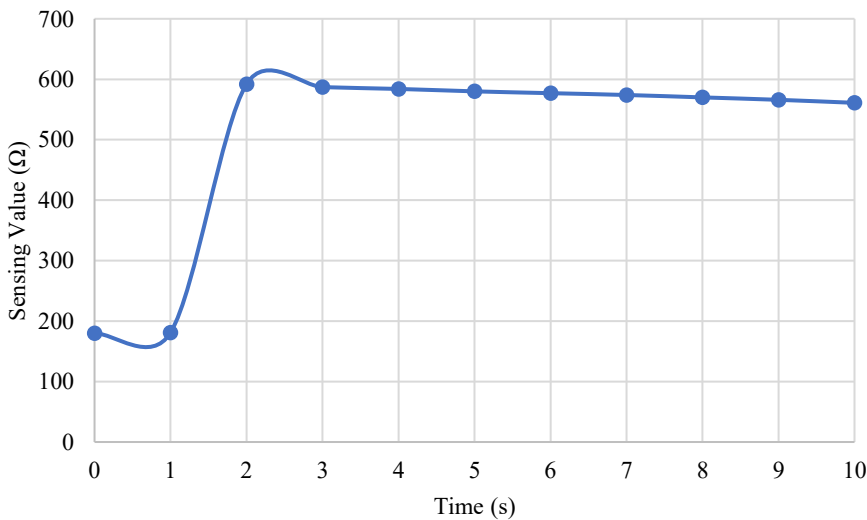

Figure 15. Alcohol sensing value when alcohol below legal limit

5.3 Graph Alcohol Sensing Value with Alcohol Above Legal Limit

In the above-legal-limit alcohol simulation, which was greater than 0.05% BAC, the sensing value from the MQ-3 alcohol sensor rose from about 180 Ω to a peak of 920 Ω. According to findings reported by Vedanarayan et al. and Neha et al. [28-29], Pelayo and Hariharan et al. [32-33], BAC of 0.05% corresponds to 800 Ω sensing value for the MQ-3 sensor. During this simulation, the sensor value also increased rapidly upon detection of alcohol. Figure 16 shows the alcohol sensing value obtained from MATLAB/Simulink during the simulation of alcohol levels above 0.05% BAC.

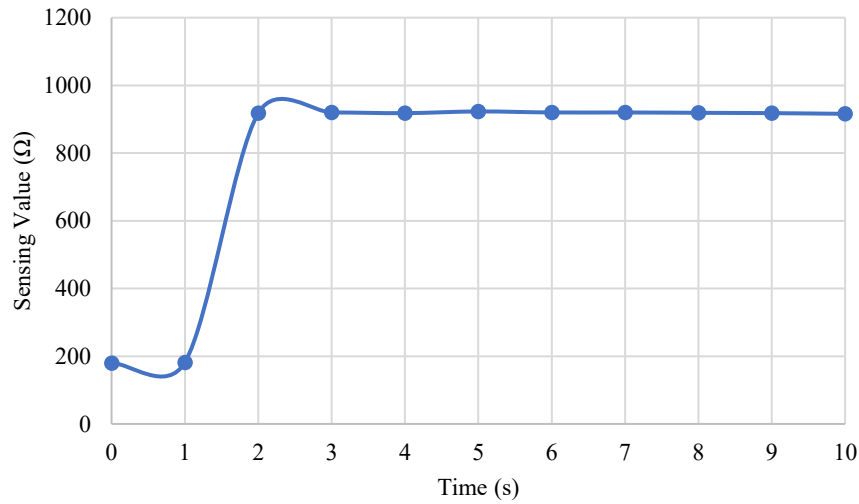

Figure 16. Alcohol sensing value when alcohol above 0.05% BAC

5.4 Prototype Testing without Alcohol Situation

During the simulation testing, the tester exhaled air toward the sensor when the system was initiated, and the alcohol sensing result was compared with the digital alcohol breathalyzer. For each test, the tester also exhaled air into the breathalyzer to ensure consistency and accuracy of the comparison. The test was carried out under different conditions, and the results are presented in Table 6.

Table 6. VADSS testing without alcohol and different situations

Situation	BAC reading from VADSS (%)	BAC reading from breathalyzer (%)	Percentage of error (%)	VADSS reaction
Not seated	0.00	0.00	0.00	Blue LED flash
Door Open				Buzzer beeping
Seated	0.00	0.00	0.00	Blue LED flash
Door Open				Buzzer beeping
Not seated	0.00	0.00	0.00	Blue LED flash
Door Close				Buzzer beeping
Seated	0.00	0.00	0.00	Green LED flash
Door Close				DC Motor running

From this testing, it was confirmed that the VADSS system did not activate the starting system even when the driver’s BAC was 0.00%, unless the driver was seated and the door was closed. The alcohol sensing result from the VADSS in this simulation was about 180 Ω, corresponding to 0.00% BAC, which matched the reading obtained from the breathalyzer.

5.5 Testing with BAC Levels Below 0.05%

During the simulation testing, the tester first consumed small amounts of Guinness beer (5.5% alcohol) to simulate different levels of BAC below the legal limit. The tester then exhaled air toward the sensor when the system was initiated, and the alcohol sensing result was compared with the digital alcohol breathalyzer. For each trial, the tester also exhaled air into the breathalyzer to ensure the accuracy and reliability of the comparison. The test was carried out under different conditions, and the results are presented in Table 7.

Table 7. VADSS Testing with alcohol below 0.05% BAC and different situations

Situation	BAC reading from VADSS (%)	BAC reading from breathalyzer (%)	Percentage of error (%)	VADSS reaction
Not seated	0.02	0.02	0.00	Blue LED flash
Door Open				Buzzer beeping
Seated	0.03	0.03	0.00	Blue LED flash
Door Open				Buzzer beeping
Not seated	0.03	0.03	0.00	Blue LED flash
Door Close				Buzzer beeping
Seated	0.04	0.04	0.00	Green LED flash
Door Close				DC Motor running

From the testing, the VADSS system also did not activate the starting system when the driver's BAC was below 0.05% until the driver was seated and the door was closed.

5.6 Testing with BAC Levels Above 0.05%

In this simulation test, a piece of tissue sprayed with different amounts of Guinness beer (5.5% alcohol) was placed on the sensor when the system was initiated. The alcohol sensing results were then compared with those from the digital alcohol breathalyzer, where the tester exhaled air from the alcohol-soaked tissue into the breathalyzer during each trial. The test was carried out under different conditions, and the results are shown in Table 8.

Table 8. VADSS testing with alcohol above 0.05% BAC and different situations

Situation	BAC reading from VADSS (%)	BAC reading from breathalyzer (%)	Percentage of error (%)	VADSS reaction
Not seated	Above 0.05	0.12	0.00	Blue LED flash
Door Open				Buzzer beeping
Seated	Above 0.05	0.12	0.00	Blue LED flash
Door Open				Buzzer beeping
Not seated	Above 0.05	0.12	0.00	Blue LED flash
Door Close				Buzzer beeping
Seated	Above 0.05	0.12	0.00	RED LED flash
Door Close				Buzzer fast beeping

From this test, the VADSS system did not activate the starting system even when the driver was seated in the driver's seat with the door closed, as the BAC level exceeded 0.05%.

5.7 Inside Vehicle Cabin Test

In this stage, the VADSS system was installed inside the vehicle cabin to ensure proper functionality under real conditions. According to Nexus IE [34], prototype testing in an actual environment allows developers to evaluate the functionality of the system under realistic circumstances and identify weaknesses that may not have been evident in previous processes. The test vehicle used was Proton Saga FLX. During the experiment, the seat load sensor was placed on the driver's seat, the MQ-3 sensor was mounted on the steering wheel, and the door switch was pressed manually. The tester was seated in the driver's seat approximately 20 cm away from the MQ-3 sensor. The door condition and driver's position were manipulated to simulate various scenarios, while the engine remained off. Table 9 shows the results of the inside vehicle cabin test.

In this test, the tester simulated different levels of BAC by spraying varying amounts of Guinness beer (5.5% alcohol) into the mouth and blowing toward the MQ-3 sensor. From the results obtained, the system performance was satisfactory, all readings were close to the expected values and consistent with the outcomes of the previous simulation test results.

Table 9. VADSS inside vehicle cabin test

Door	Seated	VADSS BAC %	VADSS Reaction
Open	Not	0.00%	Blue LED flash
Close	Not	(Sensor Value=202 Ω)	Buzzer beeping
Close	Yes		
Close	Yes	0.00%	Green LED flash
		(Sensor Value=202 Ω)	DC motor run
Open	Not	0.01%	Blue LED flash
Close	Not	(Sensor Value= 480 Ω)	Buzzer beeping
Close	Yes		
Close	Yes	0.02%	Green LED flash
		(Sensor Value= 656 Ω)	DC motor run
Open	Not	Above 0.05%	Blue LED flash
Close	Not	(Sensor Value=872 Ω)	Buzzer beeping
Close	Yes		
Close	Yes	Above 0.05%	Red LED flash
		(Sensor Value=870 Ω)	Buzzer beeping fast

5.8 Interference Testing

In the interference testing, several common liquids and gases that could potentially be present inside the vehicle cabin or emanate from other sources were tested with the VADSS to evaluate the reliability and stability of the system. The results are presented in Table 10.

Table 10. Interference testing VADSS with different types of liquid/gas

Type of Liquid/Gas	Affect	Description
Perfume	Very affect	Increase sensor value very fast when detected.
Soft Drink	No	No changes for sensor value.
Fruit Juice	No	No changes for sensor value.
Car Perfume	Minor	Causes a minor effect on alcohol sensor reading around 50 Ω.
Hand Sanitizer	Very affect	Increase sensor value very fast when detected.
Petrol & Diesel	Very affect	Increase sensor value very fast when detected.
Food/Fruit Smell	No	No changes for sensor value.

Based on the results, the VADSS was affected by certain liquids and gases. These substances are typically volatile and derived from petroleum. Petroleum is the raw material for esters used in perfumes, alcohol present in hand sanitizers, and fuels such as petrol. Other petroleum products include transportation fuels, heating and electricity-generating fuel oils, asphalt and road oil, as well as raw materials used in the production of chemicals, polymers, and synthetic materials found in everyday products [35]. Since these liquids and gases share similar chemical characteristics with drinkable alcohol, they can affect the alcohol sensor. However, under normal circumstances, the concentrations of these substances inside the vehicle cabin would not be high enough to exceed the 0.05% BAC threshold. Therefore, the VADSS would continue to function reliably even in the presence of such interference.

6. CONCLUSION

The development of the Vehicle Alcohol and Driver Seat Detection Integrated with Engine Starting System (VADSS) was successfully achieved. Through simulations and testing, it was proven that the VADSS could reduce vehicle accidents related to drunk driving. This new concept of alcohol detection, integrated with the engine starting system, was designed to prevent cheating by incorporating a seat load sensor and door sensor, thereby eliminating the possibility of drivers providing false BAC levels to the system. The VADSS is essential for enhancing road safety in Malaysia, supporting law enforcement, reducing alcohol-related accidents, and promoting responsible driving. Furthermore, the system was developed as a low-cost yet highly reliable system that required only minor modifications to existing vehicle systems. Due to its low cost and minor modifications, it is easier to be accepted by both the public and manufacturers than other products on the market nowadays. In addition, the VADSS demonstrated a fast and reliable response in disabling the starting system, thereby significantly reducing the chance of drunk driving. For future work, the VADSS will be tested across various vehicle types and technologies, with different configurations, to further validate its efficiency.

ACKNOWLEDGEMENTS

This study is supported by the Ministry of Higher Education Malaysia and Universiti Teknikal Malaysia Melaka.

CONFLICT OF INTEREST

The authors declare that there are no conflicts of interest related to this work.

AUTHORS CONTRIBUTION

A. H. Mohamed: Literature review, conceptual prototype development, fabrication and experiment

M. H. Harun: Component design and development of the VADSS algorithm

F. Ahmad: Development of VADSS block diagram and microcontroller coding

B. Z. Xian: Conceptual prototype development and fabrication

U. Ubaidillah: Theoretical framework, provide critical feedback during manuscript preparation and revision

REFERENCES

- [1] Alcohol-Impaired Driving, Traffic Safety Facts 2023, U.S. Department of Transportation, National Highway Traffic Safety Administration 2023.
- [2] B. Singichetti, *Characteristics of Initial and Repeat Alcohol Driving While Impaired (Alcohol-Dwi) License Suspensions and Impacts on Recidivism and Future Crash Events In North Carolina, 2007 - 2016*, PhD Dissertation, University of North Carolina, 2023.
- [3] National Institute on Alcohol Abuse and Alcoholism, “Alcohols's Effects on Health,” 2023.
- [4] S. Low, “Festive Drinking: How Much Alcohol Can I Have Before Driving?,” 2021. [Online] <https://www.mountelizabeth.com.sg/health-plus/article/festive-drinking-driving>.
- [5] H. S. Crombag, J. J. Child, and G. R. Sullivan, “Drunk, dangerous and delusional: how legal concept-creep risks overcriminalization,” *Wiley Online Library*, vol. 115, pp. 2200–2207, 2020.
- [6] A. M. Harper, *Drunk Driving: Existing Programs Fail to Stop the Problem*, Master Thesis, University of Wisconsin-Platteville, 2019.
- [7] J. H. Chung, E. Lee, J. Hwang, J. Park, S. Hwang, D. Youm, et al., “Fast-responding ethanol sensor with extremely low detection limit: Influence of Pt film thickness on gas sensing properties,” *Applied Surface Science*, vol. 69, p. 162618, 2025.
- [8] J. Rehm, C. Kilian, C. Ferreira-Borges, D. Jernigan, M. Monteiro, C. D. H. Parry, et al., “Alcohol use in times of the COVID 19: Implications for monitoring and policy,” *Drug and Alcohol Review*, vol. 39, pp. 301–304, 2020.
- [9] A. Roberts, J. Rogers, R. Mason, A. N. Siriwardena, T. Hogue, G. A. Whitley, et al., “Alcohol and other substance use during the COVID-19 pandemic: A systematic review,” *Drug and Alcohol Dependence*, vol. 229, p. 109150, 2021.
- [10] W. A. R. W. I. Fikry, M. A. M. Yaakub, M. A. A. Rahim, M. H. Y. M. Jelani, and A. Ruskan, “Law enforcement in ensuring the care of Hifz Al-Nafs wa Al-Aql wa Al-Mal in the case of a drunk driver,” *Advances in Social Science, Education and Humanities Research*, vol. 560, pp. 441–445, 2021.
- [11] J. Niederdeppe, R. Avery, and E. N. Miller, “Alcohol-control public service announcements (PSAs) and drunk-driving fatal accidents in the United States, 1996–2010,” *Preventive Medicine*, vol. 99, pp. 320–325, 2017.
- [12] A. Mahmood, L. Xie, Y. Jiang, P. Dillon, N. Ahuja, H. Arshad, et al., “Driving under the influence of substances and motor vehicle fatalities among older adults in the United States,” *Traffic Injury Prevention*, vol. 24, no. 5, pp. 379–386, 2023.
- [13] Linden-Carmichael, N. Ashley, Calhoun, and H. Brian, “Measuring subjective alcohol effects in daily life using contemporary young adult language,” *Experimental and Clinical Psychopharmacology*, vol. 30, no. 2, pp. 151–158, 2022.
- [14] T. W. Yap, A. F. M. Yusof, and N. C. Musa, “Effectiveness of government policies to curb drunk driving in Malaysia,” *Proceeding of the 8th International Conference on Management and Muamalah 2021 (ICoMM 2021)*, pp. 258–267, 2021.
- [15] World Health Organization, Department of Mental Health and Substance Abuse, *Global status report on alcohol and health 2018*, World Health Organization, 2018.
- [16] World Health Organization, Department of Mental Health and Substance, *Global status report on alcohol and health and treatment of substance use disorders*, World Health Organization, 2024.
- [17] A. K. Yadav and N. R. Velaga, “A comprehensive systematic review of the laboratory-based research investigating the influence of alcohol on driving behaviour,” *Transportation Research Part F: Psychology and Behaviour*, vol. 81, pp. 557–585, 2021.
- [18] A. W. Jones, “Driving under the influence of alcohol,” *Handbook of Forensic Medicine, John Wiley & Sons Ltd.*, 2022.
- [19] N. P. Dharani, M. Ismail and M. Vidhya, “Drunk and drive detection system for safety driving,” *2022 IEEE International Conference on Current Development in Engineering and Technology (CCET)*, Bhopal, India, pp. 1–5, 2022.
- [20] U. A. Okengwu and A. A. Taiwo, “Design and implementation of in-vehicle alcohol detection and speed control,” *European Journal of Electrical Engineering and Computer Science*, vol. 6, no. 5, pp. 10–16, 2022.
- [21] T. Samson, T. Adetoyese, O. Alabi, A. Olugbenga, G. Ebong and T. Bamisaye, “A framework for robust attack detection and classification using rap-densenet,” *ParadigmPlus*, vol. 4, no. 2, pp. 1–17, 2023.
- [22] A. Anuragi and D. S. Sisodia, “Emperical wavelet transform based automated alcoholism detecting using EEG signal features,” *Biomedical Signal Processing and Control*, vol. 57, p. 101777, 2020.

- [23] S. A. Hobi and D. A. Bangar, "Monitoring Pollution in Smart Cities Based on Arduino and IoT," *Babylonian Journal of Internet of Things*, vol. 2024, pp. 115-125, 2024.
- [24] L. C. Yeh, V. R. Aprow and H. Nugroho, "Interactive simulation framework for analysing tracked mobile robots in real-time," *International Journal of Automotive and Mechanical Engineering*, vol. 22, no. 1, pp. 12146-12161, 2025.
- [25] J. A. Hampton, "Testing the prototype theory of concepts," *Journal of Memory and Language*, vol. 34, pp. 686-708, 1995.
- [26] F. lang and A. Mjoberg, *Prototyping as a Requirements Engineering Technique*, Master's Thesis, Lund University, 2020.
- [27] S. Al-Youif, M. A. M. Ali, and M. N. Mohammed, "Alcohol detection for car locking system," *2018 IEEE Symposium on Computer Applications & Industrial Electronics (ISCAIE)*, Penang, Malaysia, pp. 230-233, 2018.
- [28] V. Vedanarayan, A. Jerrin Simla, S. Sivasundarapandian, R. Sakthi Prabha, T. Gomathi and A. Aranganathan, "Enhancing vehicle safety: A comprehensive approach to accident prevention through alcohol detection and ignition control," *2024 International Conference on Innovative Computing, Intelligent Communication and Smart Electrical System (ICSES)*, pp. 1-6, 2024.
- [29] N. Neha, B. S. Krishnaprasad, and M. L. J. Shruthi, "Real-time alcohol detection and response system with arduino and MQ-3 sensor integration," *7th International Conference on I-SMAC (IoT in Social, Mobile, Analytics and Cloud)(I-SMAC)*, Kirtipur, Nepal, pp. 1095-1103, 2023.
- [30] A Francis, M. W. Wilfred, and R. Sekar, "Health monitoring with alcohol detection and ignition control system using iot," *International Journal of Innovative Technology and Exploring Engineering*, vol. 8, no. 6, pp. 203-206, 2019
- [31] M. P. Hlastala, "The alcohol breath test-a review," *Journal of Applied Physiology*, vol. 84, no. 2, pp. 401-408, 1998.
- [32] R. Pelayo, "How to use the MQ-3 alcohol sensor," 2018. <https://www.teachmemicro.com/mq-3-alcohol-sensor/>.
- [33] S. Hariharan, S. Barath, R. Monica, and R. Madhumitha, "Aduino-based alcohol detection device: Enhancing in vehicle operation through sensor technology," *Asian Journal of Applied Science and Technology (AJAST)*, vol. 8, pp. 133-150, 2024.
- [34] Nexus IE, "Why Prototype Testing is Essential in Your Product Design," 2017. [Online] <https://www.nexus-ie.co.uk/why-prototype-testing-is-essential-in-your-product-design/>
- [35] Independent Statistics and Analysis, U.S. Energy Information Administration, "What are petroleum products, and what is petroleum used for?" 2022. [Online] <https://www.eia.gov/tools/faqs/faq.php?id=41&t=6>